

COMPLETE FIBER OPTIC TESTING SOLUTIONS

OLK51AMM/SM MANUAL

www.afs-europe.com

Email: sales@afs-europe.com
Tel: 00-31-342-470734
Fax: 00-31-342-422616
Video: 00-31-342-477888

Hunnenweg 7
3781 NM Voorthuizen
Postbus 111
3780 BC Voorthuizen

Terms of payment and
delivery published at Chamber
of Commerce Harderwijk
K.v.K. nr. 08077470

Rabobank
36.63.12.553
Postcheque BEF
000-1692940-96

BTW/VAT-number
NL121102609B01
Internet
www.afs-europe.com

Advanced Fiber Solutions OLK51AMM/SM Manual

May 2009

Contents:

General Description	3
Cleaning Procedures For Fiber Optic Cables	4
Warning.....	4
OM120A	5
OM120A Operating instructions	6
Units Power Source.....	7
OS400 Series	8
OS420 Operating Instructions/Interface: Multimode Source.....	8
OS430 Operating Instructions Interface: Single Mode Source	9
Product Application and Testing Guide.....	10
Watts to dB Conversion Chart.....	14
Calibration	14
Warranty	15

Email: sales@afs-europe.com
Tel: 00-31-342-470734
Fax: 00-31-342-422616
Video: 00-31-342-477888

Hunnenweg 7
3781 NM Voorthuizen
Postbus 111
3780 BC Voorthuizen

Terms of payment and
delivery published at Chamber
of Commerce Harderwijk
K.v.K. nr. 08077470

Rabobank
36.63.12.553
Postcheque BEF
000-1692940-96

BTW/VAT-number
NL121102609B01
Internet
www.afs-europe.com

AFS EUROPE

ADVANCED FIBER SOLUTIONS

General Description:

Advanced Fiber Solutions offers the complete solutions necessary for the installer to test, terminate and troubleshoot fiber optic systems. The OLK51 series is designed to allow testing of all operating parameters of fiber optic networks, including output power levels from the fiber, coupled source power and attenuation loss in a cable.

Advanced Fiber Solutions offers complete test kits for both Multimode and Singlemode applications. The OLK51MM test kit is designed for Multimode applications while the OLK51SM test kit is designed for Singlemode applications.

Kit Content:

The **OLK51MM** test kit includes the following items:

Fiber Optic Power Meter (OM120A) calibrated at 850nm, 1300nm, 1310nm, 1490nm and 1550nm

Fiber Optic Source (OS420) with an 850nm LED and a 1300nm LED One connector adaptor (ST, SC or FC)

Carrying case

Instruction manual for testing fiber Optic systems

The **OLK51SM** test kit includes the following items:

Fiber Optic Power Meter (OMI20) calibrated at 850nm, 1300nm, 1310nm, 1490nm and 1550nm.

Fiber Optic Laser Source (OS430) with a 1310nm Laser and a 1550nm Laser. One connector adaptor (ST, SC, FC or LC)

Carrying case

Instruction manual for testing fiber Optic systems

Other kit combinations exist, please visit <http://www.afs-europe.com/products/products.htm> for more details.

Add on options: The customer may also order **cable test kits** that are not in the standard kits. Reference and receive cables shall be ordered separately. The customer may also order **adaptor kits** for their specific applications.

Ask Advanced Fiber Solutions sales representatives for more details.

Email: sales@afs-europe.com
Tel: 00-31-342-470734
Fax: 00-31-342-422616
Video: 00-31-342-477888

Hunnenweg 7
3781 NM Voorthuizen
Postbus 111
3780 BC Voorthuizen

Terms of payment and
delivery published at Chamber
of Commerce Harderwijk
K.v.K. nr. 08077470

Rabobank
36.63.12.553
Postcheque BEF
000-1692940-96

BTW/VAT-number
NL121102609B01
Internet
www.afs-europe.com

AFS EUROPE

ADVANCED FIBER SOLUTIONS

Cleaning Procedures For Fiber Optic Cables:

Fiber Optic connectors are sensitive to all types of dirt and skin oil. Because the fiber size is so small, the slightest spec of dirt can cause signal blockage and attenuation to a connector end. Always avoid touching the end of the ferrule. Always keep unconnected connectors covered with dust caps. This will ensure that the fiber does not become scratched or dirt does not settle on the end of the ferrule.

When cleaning the connector use only lint free pads or isopropyl alcohol wipes. Some solvents may attack epoxy or leave residue. All Advanced Fiber Solution test kit come provided with Texwipes Alco Pads. If a connector surface can not be cleaned with a Alco Pad because it is in a bulkhead or an active device mount use canned air. Canned air sometimes leave residue if not used with caution. Spray for 3/5 seconds to ensure that propellant is removed from the nozzle.

Other optical surfaces, like the meter detector should also be cleaned with a Texwipe when necessary. After a quick rub with the Texwipe let the surface air dry before replacing the adaptor back on the detector housing.

Warning: Never look or stare directly into a fiber optic cable.

Optical radiation that is harmful to the eye may be present. This may result in permanent eye damage. While the chances of such an occurrence taking place is very unlikely it is best advised to always use the fiber Optic power meter when detecting light.

The DO' s: Always use Alco Pads for cleaning fiber optic cables. Replace dust caps on connector end when finished testing

The DONT' s: Touch the end of a cable with fingers Leave ferrule without dust caps Drop the connector on its face. Look directly into a fiber optic cable.

Email: sales@afs-europe.com
Tel: 00-31-342-470734
Fax: 00-31-342-422616
Video: 00-31-342-477888

Hunnenweg 7
3781 NM Voorthuizen
Postbus 111
3780 BC Voorthuizen

Terms of payment and
delivery published at Chamber
of Commerce Harderwijk
K.v.K. nr. 08077470

Rabobank
36.63.12.553
Postcheque BEF
000-1692940-96

BTW/VAT-number
NL121102609B01
Internet
www.afs-europe.com

AFS EUROPE

ADVANCED FIBER SOLUTIONS

OM120A:

The OM120A meter is calibrated over five wavelengths to ± 0.2 dB of the NIST standard for each wavelength through the dynamic range of the meter. The OM120A is designed to measure loss (attenuation) and output power in both Multimode and Single mode systems. The OM120A 1mm Germanium detector is potted in a threaded housing for versatility. This allows the user to interchange adaptors for numerous connector styles. *Ask Advanced Fiber Solutions sales representatives for more details on available adaptors.*

Specifications:

Model:	OM120A
Calibrated Wavelength:	850nm, 1300nm, 1310nm, 1490nm & 1550nm
Detector:	1mm Germanium
Dynamic Range:	+4dBm to -55dBm
OM120A:	
Unit Measurement:	dBm/Watts and dB
Accuracy:	+/- 0.2 dB Calibrated to NIST standard
Detector Housing:	Threaded for interchangeable adaptors
Display:	128x64 dot matrix display
Resolution:	0.01dB (Selectable between 0.01dB and 0.1dB)
Low Battery Indicator:	Yes
Auto Power Down:	Yes
Backlight:	Yes
Controls:	Five soft rubber keypads: On/Off, backlight, Range (dB&dBm), wavelength, zero ref
Serial interface:	No
Power:	2 AA' s or optional AC adaptor.
Typical Life:	20 hours continuous operation (typical)
Case Dimensions:	4.7 x 2.7 x 1.2
Operational Temp Range:	-10Deg C to 50Deg C (45% Hum, non condensing)
Storage Temp Range:	-20Deg C to 60Deg C (45% Hum, non condensing)
Regulatory Approval:	CE

Email: sales@afs-europe.com
Tel: 00-31-342-470734
Fax: 00-31-342-422616
Video: 00-31-342-477888

Hunnenweg 7
3781 NM Voorthuizen
Postbus 111
3780 BC Voorthuizen

Terms of payment and
delivery published at Chamber
of Commerce Harderwijk
K.v.K. nr. 08077470

Rabobank
36.63.12.553
Postcheque BEF
000-1692940-96

BTW/VAT-number
NL121102609B01
Internet
www.afs-europe.com

AFS EUROPE

ADVANCED FIBER SOLUTIONS

OM120A Operating instructions:

Control Key's: (All key's are rubber key pads)

1. On\Off
2. Backlight
3. Wavelength Select λ (850nm, 1300nm, 1310nm, 1490nm and 1550nm)
4. dB\dBm\W
5. Zero reference (for all specified wavelengths)

Backlight Key allows the user the option to turn the display backlight on or off.

The Wavelength select key λ allows the user to select between the calibrated wavelengths of the OM120A. All wavelengths are calibrated to ± 0.2 dB of the NIST standard.

The dB\dBm\W select key allows the user to select between absolute power, which is measured in dBm, or relative power that is measured is dB. dBm\W is referenced to 1 milliwatt and both are a function of the log scale.

The Zero reference key when in the **dBm mode** allows the users to toggle the resolution between 0.0ldB and 0.1dB

The Zero reference key when in the **dB mode** allows the user to set the input launch power to a relative dB zero reference value for easy calculation of loss and attenuation of a fiber Optic cable. For instance, if a launch cable output power value is -25.6 dBm and a test cable is inserted between the launch cable and the meter with a reading of -27.1 dBm, the user has to subtract -27.1 dBm from -25.6 dBm to get a result of -1.5 dB. As simple as this test sounds it can sometimes get confusing to the user due to the fact that they are not sure if their result should be a positive value or a negative value also miscalculation can be an issue. The zero reference function eliminates these problems. The user simply sets their reference value (which in this case is -25.6 dBm) to 0.0 dB then inserts the test cable to get a loss reading of -1.5 dB. ***EASY***.

Different references can be stored for all four wavelengths. The stored reference value will be maintained until a new reference is stored.

The screen also displays the value that the user has referenced too at the bottom left corner of the screen. This reading is the dBm (absolute) value of the users dB zero reference value.

** The OM120A also offers an **auto power down** feature. This function can be enabled or disable when the unit is powered up by pressing the λ key. When enabled the unit will shut down after 15 minutes of no key activity. The unit will signal the user that it is about to shut down by counting down the last minute in the right top corner of the screen.*

Email: sales@afs-europe.com
Tel: 00-31-342-470734
Fax: 00-31-342-422616
Video: 00-31-342-477888

Hunnenweg 7
3781 NM Voorthuizen
Postbus 111
3780 BC Voorthuizen

Terms of payment and
delivery published at Chamber
of Commerce Harderwijk
K.v.K. nr. 08077470

Rabobank
36.63.12.553
Postcheque BEF
000-1692940-96

BTW/VAT-number
NL121102609B01
Internet
www.afs-europe.com

AFS EUROPE

ADVANCED FIBER SOLUTIONS

Units Power Source:

1. 2 AA batteries
2. *Optional AC power converter.*

The battery is in the compartment at the rear of the unit.

AC adaptors are not standard with the OLK51 test kits but may be ordered separately. Ask Advanced Fiber Solutions sales representatives for more details.

Email: sales@afs-europe.com
Tel: 00-31-342-470734
Fax: 00-31-342-422616
Video: 00-31-342-477888

Hunnenweg 7
3781 NM Voorthuizen
Postbus 111
3780 BC Voorthuizen

Terms of payment and
delivery published at Chamber
of Commerce Harderwijk
K.v.K. nr. 08077470

Rabobank
36.63.12.553
Postcheque BEF
000-1692940-96

BTW/VAT-number
NL121102609B01
Internet
www.afs-europe.com

AFS EUROPE

ADVANCED FIBER SOLUTIONS

OS400 Series:

The OS400 series is a handheld fiber optic source. The OS420 Source is an LED Source for multimode applications while the OS430 Source is a Laser Source for single mode applications. The OS420 Source has two active device mount LED's; the wavelengths of the LED's are 850nm and 1300nm. The OS430 Source has two laser Sources that are packaged together internally and pigtailed to one single output with optional connector styles.

Specifications:

Model:	OS420	OS430
Wavelength:	850nm, 1300nm	1310nm, 1550nm
Type:	LED	Laser
Application:	MM	SM
Connector Style:	ST	ST, SC or FC (<i>Ask for details</i>)
Tone:	No	Yes

OS420 Operating Instructions/Interface: Multimode Source

Control indicators and switches:

- Switch: The unit has a slide switch to turn either the 1300nm LED or 850nm LED on.
Indicators: 3 LED's that indicate 1300nm on, 850nm on and low battery.
Pots: The unit has adjustment pots for both the 1300nm LED and the 850nm LED. Having both pots makes the unit user friendly for easy referencing of both LED's.

OS420 Specifications:

- Transmitters:
 - 850nm Active Device Mount.
 - 1300nm Active Device Mount.
- Connector Style: ST
- Output Power: > -20.0 dBm (for both LED's)
- Wavelength: 850nm and 1300nm
- Stability: +/- 0.2 dB (over a 8 hour period with 5 minute warm up)
- Coupled Power Ratio: 850nm category 1 (Overfill), 1300nm category 1 (Overfill) according to the TIA/EIA-526-14A Standard.
- Batteries: 2 AA
- Battery life: 16 Hours continuous operation (*typical*)
- Low Battery Indicator: Yes

Email: sales@afs-europe.com
Tel: 00-31-342-470734
Fax: 00-31-342-422616
Video: 00-31-342-477888

Hunnenweg 7
3781 NM Voorthuizen
Postbus 111
3780 BC Voorthuizen

Terms of payment and
delivery published at Chamber
of Commerce Harderwijk
K.v.K. nr. 08077470

Rabobank
36.63.12.553
Postcheque BEF
000-1692940-96

BTW/VAT-number
NL121102609B01
Internet
www.afs-europe.com

AFS EUROPE

ADVANCED FIBER SOLUTIONS

10. Serial Interface: No
11. Temperature: Operation -10 to +50 C (45% Hum, non condensing)
Storage -20 to +60 C (75% Hum, non condensing)
12. Regulatory Approval: CE

OS430 Operating Instructions/Interface: Single Mode Source

Control indicators and switches:

- Switch: The unit has 2 slide switches. A 3-position slide switch to turn the unit on/off (depending on wavelength) and a 2-position slide switch to turn 2KHz tone on/off.
- Indicators: 3 LED's that indicate 1310nm on, 1550nm on and Low battery.
- Pots: The unit has adjustment pots for both the 1310nm Laser and the 1550nm Laser. Having both pots makes the unit user friendly for easy referencing of both Lasers.

OS430 Specifications:

1. Transmitters: 1310nm/1550nm → single package → pigtail FC
2. Connector Style: ST, FC or SC (optional)
3. Output Power: > -8 dBm (for both Lasers)
4. Tone: Yes (2 KHz)
5. Wave length: 1310nm and 1550nm
6. Stability: +/- 0.25 dB (over a 8 hour period with 1 minute warm up)
7. Batteries: 2 AA
8. Battery Life: 16 Hours continuous operation
9. Low Battery Indicator: Yes
10. Serial Interface: No
11. Temperature: Operation -10 to +50 C (45% Hum, non condensing)
Storage -20 to +60 C (75% Hum, non condensing)
12. Regulatory approval: CE

Email: sales@afs-europe.com
Tel: 00-31-342-470734
Fax: 00-31-342-422616
Video: 00-31-342-477888

Hunnenweg 7
3781 NM Voorthuizen
Postbus 111
3780 BC Voorthuizen

Terms of payment and
delivery published at Chamber
of Commerce Harderwijk
K.v.K. nr. 08077470

Rabobank
36.63.12.553
Postcheque BEF
000-1692940-96

BTW/VAT-number
NL121102609B01
Internet
www.afs-europe.com

Product Application and Testing Guide

In the following testing guide a meter refers to an Advanced Fiber Solutions OM120, and a source refers to an Advanced Fiber Solutions OS420 LED source or OS430 Laser source.

Setting 0 dB loss reference for testing

This is the reference power reading that is created by placing a launch cable between the meter and the source.

Test setup:

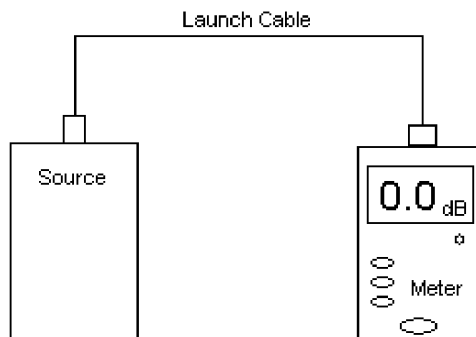

Procedure:

1. Attach launch cable to the output of the source and input of meter.
2. Make sure the output power level from the Source is over -30 dBm.
3. With meter in "dB" mode, hit the zero reference key. When the meter zeros out as illustrated in the above setup the launch reference power has been stored and the user is now ready to start testing cables.
4. Once the zero reference power has been set, do not remove the launch cable from the Source as reattaching it may change the output power level.

AFS EUROPE

ADVANCED FIBER SOLUTIONS

Fiber Optic Cable Testing Per EIA/TIA FOTP-171

One-way loss test: Tests loss of connector mated to launch cable. To test the other connector of the test cable, reverse the cable under test.

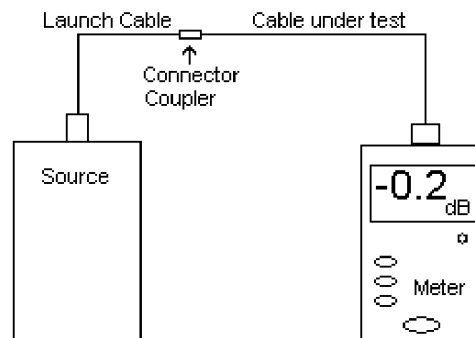

FOPT-171

Procedure:

1. Attach the test cable to the connector coupler.
2. Attach the other end of the cable to the meter and read the value.
3. The indicated value on the display will be the loss of the mated connector of the cable under test and the test cable. To test the other connector on the test cable simply reverse the cable under test and read the loss from the power meter.

Email: sales@afs-europe.com
Tel: 00-31-342-470734
Fax: 00-31-342-422616
Video: 00-31-342-477888

Hunnenweg 7
3781 NM Voorthuizen
Postbus 111
3780 BC Voorthuizen

Terms of payment and
delivery published at Chamber
of Commerce Harderwijk
K.v.K. nr. 08077470

Rabobank
36.63.12.553
Postcheque BEF
000-1692940-96

BTW/VAT-number
NL121102609B01
Internet
www.afs-europe.com

AFS EUROPE

ADVANCED FIBER SOLUTIONS

Fiber Optic Cable Testing Per EIA/TIA OFSTP-14

This test allows the user to test both connectors of the cable under test at once (Dual Connector test).

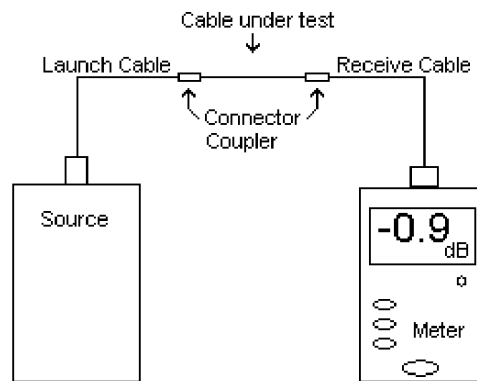

OFSTP-14

Procedure:

1. A loss reading for the receive cable should already be established by doing a single ended test on it as specified in the FOPT -171 illustration. The loss of the receive cable should be added on to the loss of the cable under test when the test is completed or zeroed out before the cable under test is placed between it and the launch cable.
2. Attach the cable under test to the launch cable.
3. Attach the other end of the cable under test to the receive cable.
4. The power indicated on the meter is the loss of the cable under test.

**When testing cables make sure that the cable under test, the receive and the launch cable have the same core and cladding size otherwise the results will not be true loss readings.*

Email: sales@afs-europe.com
Tel: 00-31-342-470734
Fax: 00-31-342-422616
Video: 00-31-342-477888

Hunnenweg 7
3781 NM Voorthuizen
Postbus 111
3780 BC Voorthuizen

Terms of payment and
delivery published at Chamber
of Commerce Harderwijk
K.v.K. nr. 08077470

Rabobank
36.63.12.553
Postcheque BEF
000-1692940-96

BTW/VAT-number
NL121102609B01
Internet
www.afs-europe.com

AFS EUROPE

ADVANCED FIBER SOLUTIONS

Measuring output power of a fiber optic transmitter/system

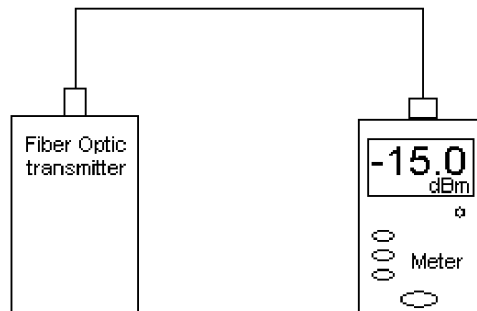

Procedure:

1. Measure output power from transmitter or at receiver by connecting to the power meter.
2. Set meter to correct wavelength.
3. Set meter to dBm for absolute power measurement.
4. Read power on meter.

Email: sales@afs-europe.com
Tel: 00-31-342-470734
Fax: 00-31-342-422616
Video: 00-31-342-477888

Hunnenweg 7
3781 NM Voorthuizen
Postbus 111
3780 BC Voorthuizen

Terms of payment and
delivery published at Chamber
of Commerce Harderwijk
K.v.K. nr. 08077470

Rabobank
36.63.12.553
Postcheque BEF
000-1692940-96

BTW/VAT-number
NL121102609B01
Internet
www.afs-europe.com

AFS EUROPE

ADVANCED FIBER SOLUTIONS

Watts to dB Conversion Chart

Conversion Chart For dB to Watts

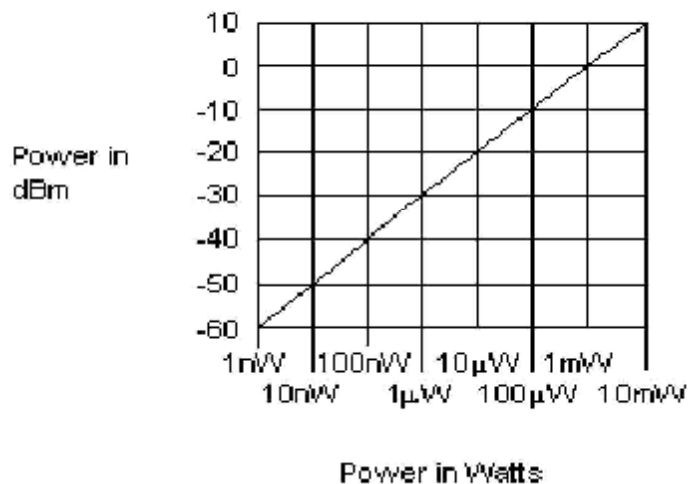

Calibration:

Every Advanced Fiber Solutions fiber optic power meter calibrated is NIST traceable. Calibration should be performed yearly by returning the unit to ADVANCED FIBER SOLUTIONS or to an ADVANCED FIBER SOLUTIONS certified calibration house.

Email: sales@afs-europe.com
Tel: 00-31-342-470734
Fax: 00-31-342-422616
Video: 00-31-342-477888

Hunnenweg 7
3781 NM Voorthuizen
Postbus 111
3780 BC Voorthuizen

Terms of payment and
delivery published at Chamber
of Commerce Harderwijk
K.v.K. nr. 08077470

Rabobank
36.63.12.553
Postcheque BEF
000-1692940-96

BTW/VAT-number
NL121102609B01
Internet
www.afs-europe.com

AFS EUROPE

ADVANCED FIBER SOLUTIONS

Warranty:

ADVANCED FIBER SOLUTIONS offers a 1 year limited warranty on all units sold (unless otherwise specified). This warranty starts on the date of Shipment of the product to its purchaser. Advanced Fiber Solutions warrants that the product or products purchased will be free of defects in workmanship and material. Advanced Fiber Solutions warrants that the product or products purchased will conform in accordance with the specifications set forth for that product or those products as published by Advanced Fiber Solutions.

ADVANCED FIBER SOLUTIONS will on written notice by the purchaser correct product/products defects by repair or replacement of that product. Advanced Fiber Solutions will incur all cost to replace or repair the product/products in question if Advanced Fiber Solutions deem that the product malfunction is without question due to a manufacturers defect. Correction as stated here in will absolve Advanced Fiber Solutions from liability due to product defects.

Advanced Fiber Solutions will not honor the warranty if the product or products in question have defects due to improper use, lack of maintenance or damage to the product or products incurred outside of the Advanced Fiber Solutions facility.

ADVANCED FIBER SOLUTIONS will in no event be liable for death, injury to persons, damage to property or equipment, loss of profits or revenues, cost of capital, claims for service interruption or cost of product replacement.

Advanced Fiber Solutions liability due to product defect will never exceed the price of that product.

ADVANCED FIBER SOLUTIONS reserves the right to make engineering improvements or changes without notice.

Email: sales@afs-europe.com
Tel: 00-31-342-470734
Fax: 00-31-342-422616
Video: 00-31-342-477888

Hunnenweg 7
3781 NM Voorthuizen
Postbus 111
3780 BC Voorthuizen

Terms of payment and
delivery published at Chamber
of Commerce Harderwijk
K.v.K. nr. 08077470

Rabobank
36.63.12.553
Postcheque BEF
000-1692940-96

BTW/VAT-number
NL121102609B01
Internet
www.afs-europe.com