

# **Basic Training Fiber Optics**

**Given by:**

***AFS EUROPE***  
***ADVANCED FIBER SOLUTIONS***

**Name student:**

.....

**© 2006 Copyright AFS Europe**

**All rights reserved. No part of this publication may be reproduced, stored in a database or retrieval system, or published, in any form or in any way, electronically, mechanically, by print, photoprint, microfilm or any other means without prior written permission from.**

**In this publication may contain brands, company names and product names of third parties, and following are the requirements for identifying trademarks and registered trademarks of those third parties. This list is not exhaustive and the site may contain brands, company names and product names of additional third parties. All brands, company names and product names are trademarks or registered trademarks of their respective holder.**

**Version 1.0**

#### **Liability**

**AFS Europe shall not be liable to you or any third party for any indirect, special, incidental, punitive, cover or consequential damages. Referring to paragraph 10 of the general terms of delivery and terms of payment.**

# Table of Contents

<b>Jargon</b> .....	<b>6</b>
<b>What is fiber optics?</b> .....	<b>7</b>
<b>Let's Start With Fiber</b> .....	<b>8</b>
<b>Terms that describe fiber optic cable:</b> .....	<b>10</b>
<b>Termination</b> .....	<b>11</b>
<b>Fiber Performance Specifications</b> .....	<b>12</b>
<b>Terms that describe the tools for installation and termination</b> .	<b>14</b>
<b>Terms that describe test equipment</b> .....	<b>16</b>
<b>Basics</b> .....	<b>18</b>
<b>Getting Started in Fiber Optics</b> .....	<b>19</b>
<b>A short history about “Fiber Optics”</b> .....	<b>20</b>
<b>Which Fiber Optics?</b> .....	<b>21</b>
<b>Outside Plant (OSP)</b> .....	<b>22</b>
<b>Premises Cabling</b> .....	<b>24</b>
<b>The Installers</b> .....	<b>26</b>
<b>Standards</b> .....	<b>28</b>
<b>Before we get started - Safety First!</b> .....	<b>30</b>
<b>Zero Tolerance for Dirt</b> .....	<b>32</b>
<b>Fiber</b> .....	<b>33</b>
<b>Fiber Specifications</b> .....	<b>34</b>
<b>Fiber Itself</b> .....	<b>35</b>
<b>Multimode &amp; Singlemode Fibers</b> .....	<b>36</b>
<b>Size Matters</b> .....	<b>38</b>
<b>Cable</b> .....	<b>40</b>
<b>Fiber Optic Cables</b> .....	<b>41</b>
<b>Cable Types</b> .....	<b>43</b>
<b>Cable Design Criteria</b> .....	<b>46</b>
<b>Choosing A Cable</b> .....	<b>48</b>
<b>Pulling Fiber Optic Cable</b> .....	<b>49</b>
<b>Cable Plant Hardware - fitting the pieces of the puzzle together!</b> .....	<b>51</b>
<b>Terminations</b> .....	<b>53</b>
<b>Termination</b> .....	<b>54</b>
<b>Connectors</b> .....	<b>55</b>
<b>Connector and Splice Loss Mechanisms</b> .....	<b>56</b>
<b>Guide to Fiber Optic Connectors</b> .....	<b>60</b>

Connector Types .....	64
Connector Ferrule Shapes & Polishes.....	65
Termination Procedures .....	67
Hints for doing field terminations.....	71
Splicing .....	73
Which Splice ? .....	75
<b>Networks .....</b>	<b>76</b>
Fiber Optic Networks .....	77
Designing Cable Networks.....	79
Industrial Networks.....	82
Long Cable Runs.....	83
Centralized Fiber LANs .....	84
High Speed Networking .....	85
Bottom Line.....	86
<b>Estimating and Bidding .....</b>	<b>87</b>
Estimating and Bidding .....	88
Bidding.....	91
Documentation .....	92
Estimating Software .....	93
<b>Testing.....</b>	<b>94</b>
Testing.....	95
Getting started .....	96
Visual Inspection.....	98
Testing loss .....	102
Troubleshooting Hints .....	106
OTDR Testing.....	107
How OTDRs Work.....	108
OTDR Limitations .....	111
Using The OTDR .....	112
Restoration .....	113
<b>Glossary .....</b>	<b>114</b>
Glossary Of Fiber Optic Terms .....	115
<b>Additional information .....</b>	<b>133</b>
Understanding OTDRs.....	134
When Do You Use OTDRs?.....	135
How Does an OTDR work? .....	137
Scattering in an optical fiber.....	138

**Information in the OTDR Trace..... 141**  
**Understanding the Physics (and Errors) of the Measurement. 143**  
**Overload Recovery ..... 144**  
**Ghosts..... 146**  
**Backscatter Variability Errors ..... 148**  
**Overcoming Backscatter Errors ..... 151**  
**Resolution Limitations ..... 152**  
**Special Consideration for Multimode Fiber..... 154**  
**Measuring Fiber, not Cable Distance ..... 156**  
**Examples of How to Use the OTDR and Avoid Errors..... 157**  
**What Does a Good OTDR Trace Look Like? ..... 158**  
**This "Trick" Can Help..... 160**  
**Summary ..... 163**  
**Notes ..... 164**

# ***Jargon***

## What is fiber optics?

- **Picture sending signals zipping along from one location to another in the form of light guided through thin fibers of glass or plastic. These signals can be analog or digital - voice, data or video information and fiber can transport more information longer distances in less time than any copper wire.**
- **It's powerful and fast, fast, fast!**
- **First get to know the language - the "jargon" - here's a list of terms you should get to know:**
  - **Metric System: Fiber Optics, as a universal technology, utilizes the metric system as the standard form of measurement. Several of the more common terms:**
    - **Meter: 39.37 inches.**
    - **Kilometer: 1.000 meters / 3,281 feet / 0.62 miles.**
    - **Micron: 1/1.000.000 th of a meter. 25 microns equal 0,001 inch. This is the common term of measurement for fibers.**
    - **Nanometer: One billionth of one meter. This term is commonly used in the fiber optics industry to express wavelength (or color) of transmitted light.**

# Let's Start With Fiber

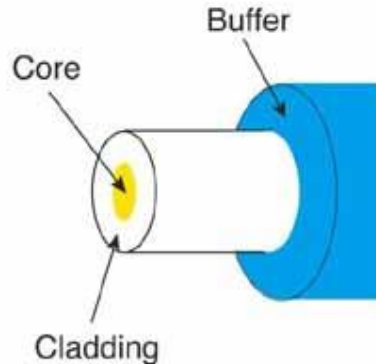

- **Optical Fiber:**  
Thin strands of highly transparent glass or sometimes plastic that guide light.
- **Core:**  
The center of the fiber where the light is transmitted.
- **Cladding:**  
The outside optical layer of the fiber that traps the light in the core and guides it along - even through curves.
- **Buffer coating or primary coating:**  
A hard plastic coating on the outside of the fiber that protects the glass from moisture or physical damage.
- **Mode:**  
A single electromagnetic field pattern (think of a ray of light) that travels in fiber.



- **Multimode fiber:**  
Has a bigger core (almost always 62,5 microns - a micron is one one millionth of a meter - but sometimes 50 microns) and is used with LED sources at wavelengths of 850 and 1300 nm for short distance, lower speed networks like LANs.
- **Singlemode fiber:**  
Has a much smaller core, only about 9 microns, and is used for telephony and CATV with laser sources at 1300 and 1550 nm. It can go very long distances at very high speeds.  
Both multimode and singlemode fiber have an outside diameter of 125 microns - about 5 thousandths of an inch - just slightly larger than a human hair.
- **Plastic optical fiber (POF):**  
Is a large core (about 1mm) multimode fiber that can be used for short, low speed networks. POF is used in consumer HiFi and starting to be used as part of a new standard for car communication systems called MOST.

## Terms that describe fiber optic cable:

- **Cable:**

Fiber needs protection to survive all the places it gets installed and it's the cable that provides it. Cables may have from one to hundreds of fibers inside.

- **Jacket:**



The tough outer covering on the cable. Cables installed inside buildings must meet fire codes by using special jacketing materials.

- **Strength members:**

Aramid fibers (Kevlar) used to pull the cable. The term is also used for the fiberglass rod in some cables used to stiffen it to prevent kinking.

- **Armor:**

Discourages rodents from chewing through it.

## Termination

- **Connector:**



**A non-permanent device for connecting two fibers or fibers to equipment where they are expected to be disconnected occasionally for testing or rerouting. It also provides protection to both fibers. (Parts for an ST connector are shown.)**

- **Ferrule:**

**A tube which holds a fiber for alignment, usually part of a connector.**

- **Splice:**

**A permanent joint between two fibers.**

- **Mechanical Splice:**

**A splice where the fibers are aligned created by mechanical means.**

- **Fusion Splice:**

**A splice created by welding or fusing two fibers together.**

- **Fusion Splicer:**

**An instrument that splices fibers by fusing or welding them, typically by electrical arc.**

- **Hardware:**

**Terminations and Splices require hardware for protection and management: patch panels, splice closures, etc.**

# Fiber Performance Specifications

**Terms you use when you want to take your measurements:**

**- Attenuation:**

**The reduction in optical power as it passes along a fiber, usually expressed in decibels (dB). See optical loss.**

**- Bandwidth:**

**The range of signal frequencies or bit rate within which a fiber optic component, link or network will operate.**

**- Decibels (dB):**

**A unit of measurement of optical power which indicates relative power. A -10 dB means a reduction in power by 10 times, -20 dB means another 10 times or 100 times overall, -30 means another 10 times or 1000 times overall and so on.**

**- dB:**

**Optical power referenced an arbitrary zero level.**

**- dBm:**

**Optical power referenced to 1 milliwatt.**

**- Micron (m):**

**A unit of measure used to measure wavelength of light.**

**- Nanometer (nm):**

**A unit of measure used to measure the wavelength of light (meaning one one-billionth of a meter).**

- **Optical Loss:**  
The amount of optical power lost as light is transmitted through fiber, splices, couplers, etc, expressed in dB.
- **Optical Power:**  
Is measured in "dBm", or decibels referenced to one milliwatt of power. While loss is a relative reading, optical power is an absolute measurement, referenced to standards. You measure absolute power to test transmitters or receivers and relative power to test loss.
- **Scattering:**  
The change of direction of light after striking small particles that causes loss in optical fibers and is used to make measurements by an OTDR.
- **Wavelength:**

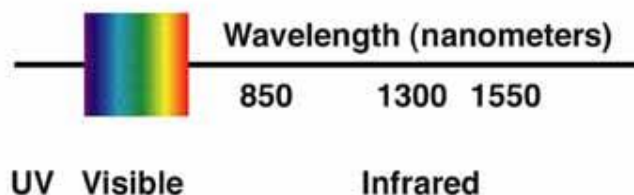

A term for the color of light, usually expressed in nanometers (nm) or microns (m). Fiber is mostly used in the infrared region where the light is invisible to the human eye.

## Terms that describe the tools for installation and termination

- **Jacket Slitter or Stripper:**  
A cutter for removing the heavy outside jacket of cables.
- **Fiber Stripper:**  
A precise stripper used to remove the buffer coating of the fiber itself for termination. There are different types in common use.
- **Cleaver:**  
A tool that precisely "breaks" the fiber to produce a flat end for polishing or splicing.

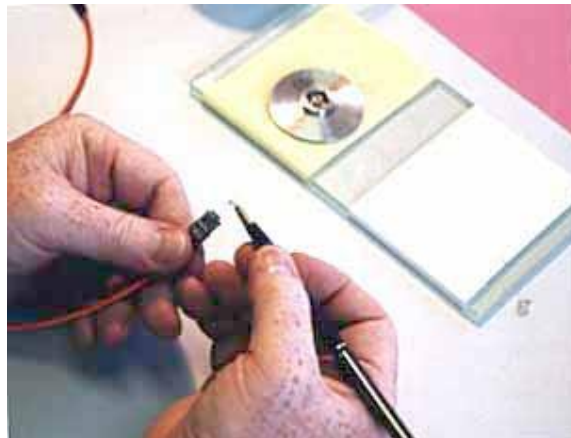

- **Scribe:**  
A hard, sharp tool that scratches the fiber to allow cleaving.

- **Polishing Puck:**  
For connectors that require polishing, the puck holds the connector in proper alignment to the polishing film.
- **Polishing Film:**  
Fine grit film used to polish the end of the connector ferrule.
- **Crimper:**  
A tool that crimps the connector to the aramid fibers in the cable to add mechanical strength.

## **Terms that describe test equipment**

- **Optical Power Meter:**  
An instrument that measures optical power from the end of a fiber.
- **Test Source:**  
An instrument that uses a laser or LED to send an optical signal into fiber for testing loss of the fiber.
- **Optical Loss Test Set (OLTS):**  
A measurement instrument for optical loss that includes both a meter and source.
- **Reference Test Cables:**  
Short, single fiber cables with connectors on both ends, used to test unknown cables.
- **Mating Adapter:**  
Also called splice bushing or couplers, allow two cables with connectors to mate.
- **Fiber Tracer:**  
An instrument that allows visual checking of continuity and tracing for correct connections.
- **Visual Fault Locator:**  
A device that allows visual tracing and testing of continuity.
- **Microscope:**  
Used to inspect the end surface of a connector for flaws or dirt.



- **OTDR:**

**An instrument that uses backscattered light to find faults in optical fiber and infer loss from only one end of the cable.**

# ***Basics***

## **Getting Started in Fiber Optics**

- **You need tools, test equipment and - most of all - training!**
- **This training will help you get started by providing very basic information and demonstrating that you don't need to break the bank to break into the field.**

## **A short history about “Fiber Optics”**

- **It's the communications technology that works by sending signals down hair thin strands of glass fiber (and sometimes plastic fiber.) It began about 30 years ago in the R&D labs (Corning, Bell Labs, ITT UK, etc.) and was first installed in Chicago in 1976. By the early 1980s, fiber networks connected the major cities on each coast.**
- **By the mid-80s, fiber was replacing all the telco copper, microwave and satellite links. In the 90s, CATV discovered fiber and used it first to enhance the reliability of their networks, a big problem. Along the way, they discovered they could offer phone and Internet service on that same fiber and greatly enlarged their markets.**
- **Computers and LANs started using fiber about the same time as the telcos. Industrial links were among the first as the noise immunity of fiber and its distance capability make it ideal for the factory floor. Mainframe storage networks came next, the predecessors of today's fiber SANs (storage area networks.)**
- **Other applications developed too: aircraft, ship and automobile data buses, CCTV for security, even links for consumer digital stereo!**
- **Today fiber optics is either the dominant medium or a logical choice for every communication system.**

## **Which Fiber Optics?**

- **Whenever you read an article or talk to someone about fiber optics, you need to know the point of view of the writer. Fiber optics, you see, is not all the same. Is the writer discussing "outside plant" fiber optics as used in telephone networks or CATV. Or is the article about "premises" fiber optics as found in buildings and campuses?**
- **Just like "wire" which can mean lots of different things - power, security, HVAC, CCTV, LAN or telephone - fiber optics is not all the same. And this can be a big source of confusion to the novice. Lets define our terms.**

## Outside Plant (OSP)

- **Telephone companies, CATV and the Internet all use lots of fiber optics, most of which is outside buildings. It hangs from poles, is buried underground, pulled through conduit or is even submerged underwater. Most of it goes relatively long distances, from a few thousand feet to hundreds of miles.**



- **Outside plant installations are all singlemode fiber (we'll define the fiber types in the next chapter), and cables often have very high fiber counts, up to 288 fibers. Cable designs are optimized for resisting moisture and rodent damage. Installation requires special pullers or plows, and even trailers to carry giant spools of cable.**
- **Long distances mean cables are spliced together, since cables are not longer than about 4 km (2,5 miles), and most splices are by fusion splicing. Connectors (SC, ST or FC styles) on factory made pigtails are spliced onto the end of the cable. After installation, every fiber and every splice is tested with an OTDR.**
- **If this sounds like big bucks, you are right! The installer usually has a temperature controlled van or**

**trailer for splicing and/or a bucket truck. Investments in fusion splicers and OTDRs can add up to over €80.000 alone.**

- **Contractors doing outside plant work are few and far between. Most outside plant telephone installs are done by the telco themselves, while a small number of large, specialized installers do CATV work.**

## Premises Cabling

- **By contrast, premises cabling- cabling installed in a building or campus - involves short lengths, rarely longer than a few hundred feet, with 2 to 48 fibers per cable typically. The fiber is mostly multimode, except for the enlightened user who installs hybrid cable with both multimode and singlemode fibers.**



- **Splicing is practically unknown in premises applications. Cables between buildings can be bought with double jackets, PE for outside plant protection over PVC for building applications requiring flame retardant cable jackets, so cables can be run continuously between buildings. Today's connectors often have lower loss than splices, and patch panels give more flexibility for moves, adds and changes.**
- **Most connectors are ST style with a few SCs here and there. Termination is by installing connectors directly on the ends of the fibers, primarily using adhesive technology or occasionally some other variety of termination method. Testing is done by a source and meter, but every installer should have a flashlight type tracer to check fiber continuity and connection.**



- **Unlike the outside plant technician, the premises cabler (who is often also installing the power cable and Cat 5 for LANs too!) probably has an investment of less than €1.500 in tools and test equipment.**
- **There are thousands of cabling installers who do fiber optic work. They've found out it isn't "rocket science", and their small initial investment in training, tools and test equipment is rapidly paid back.**

## The Installers

- **Few installers do both outside plant and premises cabling. The companies that do are usually very large and often have separate divisions doing each with different personnel. Most contractors do nothing but premises cabling.**
- **Fiber vs Copper you may be surprised by who wins this contest!**
- **If you are already terminating copper wire then you are well along in learning to install fiber.**
- **Twenty years ago, fiber was just being introduced and required PhD's from Bell Labs to install it while copper wire was easy to install. Today it is often the opposite. Because fiber is so powerful, at today's network speeds fiber is hardly working hard at all and can look to the future of ten gigabit speeds with confidence. Copper on the other hand, can handle gigabit Ethernet but only if it is carefully installed and tested with very expensive test equipment and components. Even the experts have to be very careful because it has little "headroom".**
- **Also, if you are currently working with copper, you also have to know that LAN copper cable is delicate. It only has a 25 pound (11,34 kg) pulling tension limit and kinks will ruin the high speed performance. With fiber - even though it's glass fiber - it has more strength and greater tolerance to abuse than copper wire. (What do you think gives the strength to your "fiberglass" boat?)**

- **OK, you might say, I can buy everything you've said so far, but isn't fiber more expensive?**
- **Telcos and CATV operators use fiber because it's much cheaper. They optimize their network to take advantage of fiber's speed and distance advantages. In LANs, you need to follow the new EIA/TIA 568 B.3 standard to optimize the fiber usage, and then it can be cheaper than copper. How about test equipment? Guess again Fiber optic test equipment costs lots less than Cat 5E/6 testers. See the chapter Networks where we will show you how the setup for a fiber network has some surprising savings.**
- **The Secret To Success In Fiber Optics Is Training!**
- **You wouldn't try to drive a truck or fly a plane without taking lessons. Likewise for improving your golf or tennis game. Well, the secret to fiber optics is training too. With some basic knowledge and hands-on practice gained in a training course, fiber is pretty easy to install.**

## Standards

- **ANSI, American National Standardisation Institute.**
- **EIA/TIA, Electronic Industry Association/Telecommunications Industry Association.**
- **ISO/IEC, International Standards Organisation/International Electrotechnical Commission.**
- **CENELEC, Comité Européen de Normalisation Electrotechnique.**
- **IEEE 802.3j standard for 10Base-F (FP, FB, & FL) was released which permitted attachment over longer distances (2000 meters) via two fiber optic cables. This standard updated and expanded the earlier FOIRL standard.**
- **The IEEE 802.3z defines the Gigabit Ethernet over fiber and cable, which has a physical media standard 1000Base-X (1000BaseSX - short wave covers up to 500m, and 1000BaseLX - long wave covers up to 5km). The IEEE 802.3ab defines the Gigabit Ethernet over the unshielded twisted pair wire (1000Base-T covers up to 75m). The Gigabit interface converter (GBIC) allows network managers to configure each gigabit port on a port-by-port basis for short-wave (SX), long-wave (LX), long-haul (LH), and copper physical interfaces (CX). LH GBICs extended the single-mode fiber distance from the standard 5 km to 10 km.**

- **ISO/IEC 14763 Part 3, This standard incorporates innovations and recent developments including guidance in the proper use of uni-directional and bi-directional OTDR testing, the three-jumper method as default test method, fibre end-face inspection and criteria for scratches, return loss values for SC and non-SC connectors and the normative use of reference connectors. However, the most substantial change is the application of the 2 parameters which are used to determine the two repeatable multimode launch conditions “modal power distribution” and “coupled power ratio”.**

## **Before we get started - Safety First!**

- **You might think that eye damage from working with lasers would be the big concern in fiber optic installations. The reality is that high power lasers burning holes in metal or burning off warts mostly have little relevance to your typical fiber optic installation. Optical sources used in fiber optics are of much lower power levels (the exception is high power DWDM or CATV systems). Of course, you should always be careful with your eyes, especially when using a fiber optic microscope. NEVER look into a fiber unless you know no light is present - use a power meter to check it - and anyway, the light is in the infrared and you can't see anything anyway!**
- **The real safety lecture will always be about small scraps of glass cleaved off the ends of the fibers being terminated or spliced. These scraps are very dangerous! The cleaved ends are extremely sharp and can easily penetrate your skin. If they get into your eyes, they are very hard to flush out. Don't even think about what happens if you eat one. Safety glasses are a must!**

**Always follow these rules when working with fiber:**

- 1. Dispose of all scraps properly.**
  - 2. Always use a properly marked container to dispose of later and work on a black pad which makes the slivers of glass easier to spot.**
  - 3. Do not drop them on the floor where they will stick in carpets or shoes and be carried elsewhere.**
  - 4. Do not eat or drink anywhere near the work area.**
- Fiber optic splicing and termination use various chemical adhesives and cleaners as part of the processes. Follow the instructions for use carefully. Remember, even simple isopropyl alcohol, used as a cleaner, is flammable.**

## **Zero Tolerance for Dirt**

- **With fiber optics, our tolerance to dirt is near zero. Airborne particles are about the size of the core of SM fiber- they absorb lots of light and may scratch connectors if not removed! Dirt on connectors is the biggest cause of scratches on polished connectors and high loss measurements!**
  - 1. Try to work in a clean area. Avoid working around heating outlets, as they blow dust all over you.**
  - 2. Always keep dust caps on connectors, bulkhead splices, patch panels or anything else that is going to have a connection made with it.**
  - 3. Use lint free pads and isopropyl alcohol to clean the connectors.**
  - 4. Ferrules on the connectors/cables used for testing will get dirty by scraping off the material of the alignment sleeve in the splice bushing - creating a 1-2 dB attenuator. You can see the front edge of the connector ferrule getting black! Use the metal or ceramic alignment sleeve bulkheads only for testing.**



# ***Fiber***

## **Fiber Specifications**

**The usual fiber specifications you will see are size, attenuation and bandwidth. While manufacturers have other specs that concern them, like numerical aperture (the acceptance angle of light into the fiber), ovality (how round the fiber is), concentricity of the core and cladding, etc., these specs do not affect you.**

## Fiber Itself

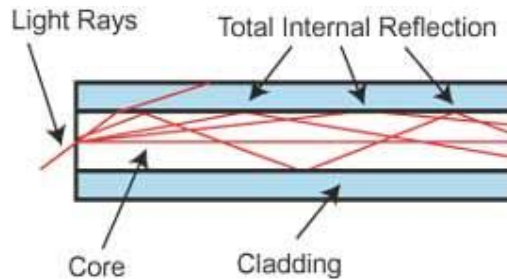

- **Fiber Optics, as we said, is sending signals down hair-thin strands of glass or plastic fiber. The light is "guided" down the center of the fiber called the "core". The core is surrounded by a optical material called the "cladding" that traps the light in the core using an optical technique called "total internal reflection." The core and cladding are usually made of ultra-pure glass, although some fibers are all plastic or a glass core and plastic cladding. The fiber is coated with a protective plastic covering called the "primary buffer coating" that protects it from moisture and other damage. More protection is provided by the "cable" which has the fibers and strength members inside an outer covering called a "jacket".**

## Multimode & Singlemode Fibers

- **Multimode & Singlemode fiber are the two types of fiber in common use. Both fibers are 125 microns in outside diameter - a micron is one one-millionth of a meter and 125 microns is 0,005 inches- a bit larger than the typical human hair.**
- **Multimode fiber has light traveling in the core in many rays, called modes. It has a bigger core (almost always 62,5 microns, but sometimes 50 microns ) and is used with LED sources at wavelengths of 850 and 1300 nm (see below!) for slower local area networks (LANs) and lasers at 850 and 1310 nm for networks running at gigabits per second or more.**
- **Singlemode fiber has a much smaller core, only about 9 microns, so that the light travels in only one ray. It is used for telephony and CATV with laser sources at 1300 and 1550 nm.**
- **Plastic Optical Fiber (POF) is large core ( about 1mm) fiber that can only be used for short, low speed networks.**

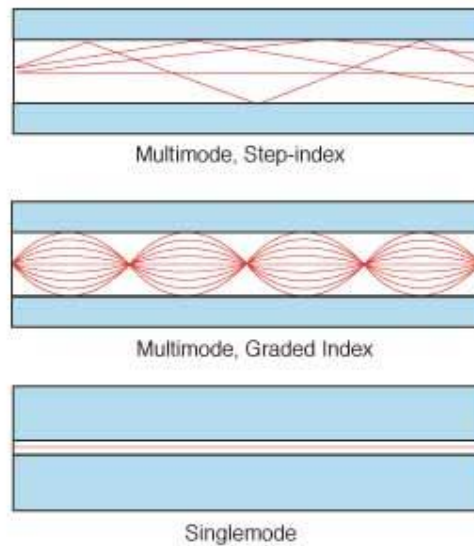

- **Step index multimode was the first fiber design but is too slow for most uses, due to the dispersion caused by the different path lengths of the various modes. Step index fiber is rare - only POF uses a step index design today.**
- **Graded index multimode fiber uses variations in the composition of the glass in the core to compensate for the different path lengths of the modes. It offers hundreds of times more bandwidth than step index fiber - up to about 2 gigahertz.**
- **Singlemode fiber shrinks the core down so small that the light can only travel in one ray. This increases the bandwidth to almost infinity - but it's practically limited to about 100.000 gigahertz - that's still a lot!**

## Size Matters

- **Fiber, as we said, comes in two types, singlemode and multimode. Except for fibers used in specialty applications, singlemode fiber can be considered as one size and type. If you deal with long haul telecom customers, you may have to work with manufacturers on specialty singlemode fibers.**
- **Multimode fibers originally came in several sizes, optimized for various networks and sources, but the data industry standardized on 62,5 core fiber in the mid-80s (62,5/125 fiber has a 62,5 micron core and a 125 micron cladding.) Recently, as gigabit and 10 gigabit networks have become widely used, an old fiber has been revived. The 50/125 fiber was used from the late 70s with lasers for telecom applications before singlemode fiber became available. It offers higher bandwidth with the laser sources used in the gigabit LANs and can go longer distances. While it still represents a smaller volume than 62.5/125, it is growing.**

<b>Fiber Types and Typical Specifications</b>			
<b>Core/Cladding</b>	<b>Attenuation</b>	<b>Bandwidth</b>	<b>Applications/Notes</b>
<b>Multimode Graded-Index</b>			
	<b>@850/1300 nm</b>	<b>@850/1300 nm</b>	
<b>50/125 microns</b>	<b>3/1 dB/km</b>	<b>500/500 MHz-km</b>	<b>Laser-rated for GbE LANs</b>
<b>50/125</b>	<b>3/1 dB/km</b>	<b>2000/500</b>	<b>Optimized for</b>

<b>microns</b>		<b>MHz-km</b>	<b>850 nm VCSELs</b>
<b>62.5/125 microns</b>	<b>3/1 dB/km</b>	<b>160/500 MHz-km</b>	<b>Most common LAN fiber</b>
<b>100/140 microns</b>	<b>3/1 dB/km</b>	<b>150/300 MHz-km</b>	<b>Obsolete</b>
<b>Singlemode</b>			
	<b>@1310/1550 nm</b>		
<b>8-9/125 microns</b>	<b>0.4/0.25 dB/km</b>	<b>HIGH! ~ 100 Terahertz</b>	<b>Telco/CATV/long high speed LANs</b>
<b>Multimode Step-Index</b>			
	<b>@850 nm</b>	<b>@850 nm</b>	
<b>200/240 microns</b>	<b>4-6 dB/km</b>	<b>50 MHz-km</b>	<b>Slow LANs &amp; links</b>
<b>POF (plastic optical fiber)</b>			
	<b>@ 650 nm</b>	<b>@ 650 nm</b>	
<b>1 mm</b>	<b>~ 1 dB/m</b>	<b>~ 5 MHz-km</b>	<b>Short Links &amp; Cars</b>

### **CAUTION:**

**You cannot mix and match fibers! Trying to connect singlemode to multimode fiber can cause 20 dB loss - that's 99% of the power. Even connections between 62.5/125 and 50/125 can cause loss of 3 dB or more - over half the power.**

# ***Cable***



## **Fiber Optic Cables**

**Fiber optic "cable" refers to the complete assembly of fibers, strength members and jacket. Fiber optic cables come in lots of different types, depending on the number of fibers and how and where it will be installed. Choose cable carefully as the choice will affect how easy it is to install, splice or terminate and, most important, what it will cost!**

**Choosing a cable - what hazards will it face?**

**Cable's job is to protect the fibers from the hazards encountered in an installation. Will the cables be exposed to chemicals or have to withstand a wide temperature range? What about being gnawed on by a woodchuck or another animal? Inside buildings, cables don't have to be so strong to protect the fibers, but they have to meet all fire code provisions. Outside the building, it depends on whether the cable is buried directly, pulled in conduit, strung aerially or whatever. Your best bet is to contact a few cable manufacturers (two minimum, three preferred) and give them the specs. They will want to know where the cable is going, how many fibers you need and what kind (singlemode or multimode or both in what we call "hybrid" cables.) You can also have a "composite" cable that includes copper conductors for signals or power. The cable companies will evaluate your requirements and make suggestions. Then you can get competitive bids.**

**Since the plan will call for a certain number of fibers, consider adding spare fibers to the cable - fibers are cheap! That way, you won't be in trouble if you break a fiber or two when splicing, breaking-out or terminating fibers. And request the end user consider their future expansion needs. Most users install lots more fibers than needed, especially adding singlemode fiber to multimode fiber cables for campus or backbone applications.**

## Cable Types

**Cables (from left to right):**

**Zipcord, Distribution, Loose Tube, Breakout.**

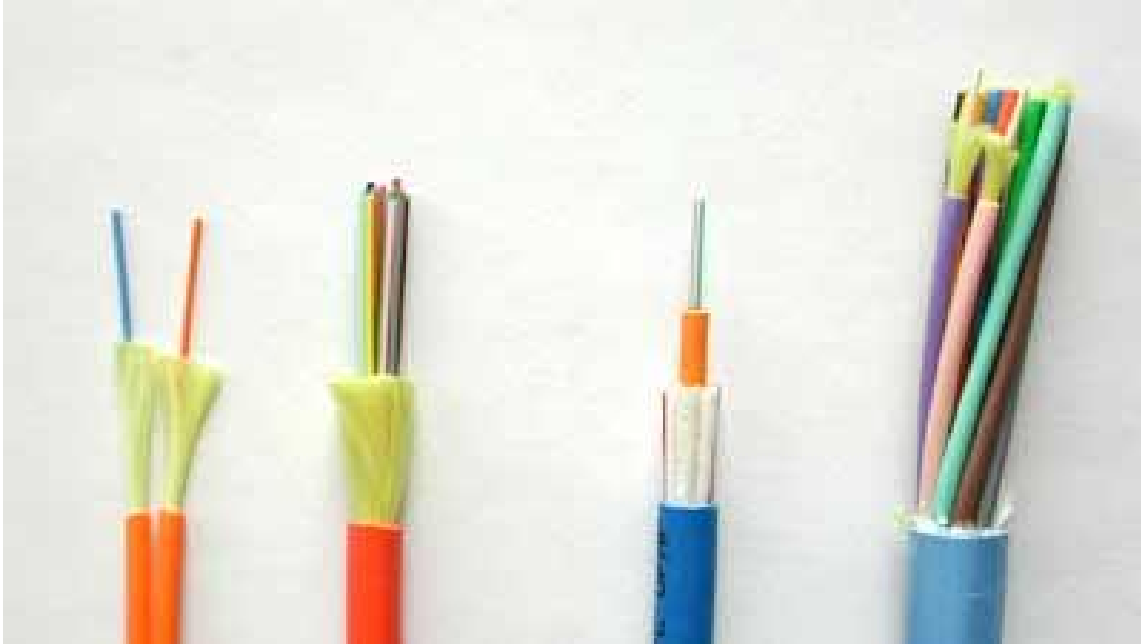

- **Simplex and zip cord:**  
Simplex cables are one fiber, tight-buffered (coated with a 900 micron buffer over the primary buffer coating) with Kevlar (aramid fiber) strength members and jacketed for indoor use. The jacket is usually 3mm (1/8 in.) diameter. Zipcord is simply two of these joined with a thin web. It's used mostly for patch cord and backplane applications, but zipcord can also be used for desktop connections.
- **Distribution cables:**  
They contain several tight-buffered fibers bundled under the same jacket with Kevlar strength

members and sometimes fiberglass rod reinforcement to stiffen the cable and prevent kinking. These cables are small in size, and used for short, dry conduit runs, riser and plenum applications. The fibers are double buffered and can be directly terminated, but because their fibers are not individually reinforced, these cables need to be broken out with a "breakout box" or terminated inside a patch panel or junction box.

- **Breakout cables:**

They are made of several simplex cables bundled together. This is a strong, rugged design, but is larger and more expensive than the distribution cables. It is suitable for conduit runs, riser and plenum applications. Because each fiber is individually reinforced, this design allows for quick termination to connectors and does not require patch panels or boxes. Breakout cable can be more economic where fiber count isn't too large and distances too long, because it requires so much less labor to terminate.

- **Loose tube cables:**

These cables are composed of several fibers together inside a small plastic tube, which are in turn wound around a central strength member and jacketed, providing a small, high fiber count cable. This type of cable is ideal for outside plant trunking applications, as it can be made with the loose tubes filled with gel or water absorbent powder to prevent harm to the fibers from water. It can be

**used in conduits, strung overhead or buried directly into the ground. Since the fibers have only a thin buffer coating, they must be carefully handled and protected to prevent damage.**

**- Ribbon Cable:**

**This cable offers the highest packing density, since all the fibers are laid out in rows, typically of 12 fibers, and laid on top of each other. This way 144 fibers only has a cross section of about 1/4 inch or 6 mm! Some cable designs use a "slotted core" with up to 6 of these 144 fiber ribbon assemblies for 864 fibers in one cable! Since it's outside plant cable, it's gel-filled for water blocking.**

**- Armored Cable:**

**Cable installed by direct burial in areas where rodents are a problem usually have metal armoring between two jackets to prevent rodent penetration. This means the cable is conductive, so it must be grounded properly.**

**- Aerial cable:**

**Aerial cables are for outside installation on poles. They can be lashed to a messenger or another cable (common in CATV) or have metal or aramid strength members to make them self supporting.**

**- Even More Types Are Available:**

**Every manufacturer has it's own favorites, so it's a good idea to get literature from as many cable makers as possible. And check out the little guys; often they can save you a bundle by making special cable just for you, even in relative small quantities.**

## Cable Design Criteria

- **Pulling Strength:**

Some cable is simply laid into cable trays or ditches, so pull strength is not too important. But other cable may be pulled thorough 2 km or more of conduit. Even with lots of cable lubricant, pulling tension can be high. Most cables get their strength from an aramid fiber (Kevlar), a unique polymer fiber that is very strong but does not stretch - so pulling on it will not stress the other components in the cable. The simplest simplex cable has a pull strength of 100-200 pounds (45-90 kg), while outside plant cable may have a specification of over 800 pounds (360 kg).

- **Water Protection:**

Outdoors, every cable must be protected from water or moisture. It starts with a moisture resistant jacket, usually PE (polyethylene), and a filling of water-blocking material. The usual way is to flood the cable with a water-blocking gel. It's effective but messy - requiring a gel remover (use the commercial stuff - it's best- -but bottled lemon juice works in a pinch!). A newer alternative is dry water blocking using a miracle powder - the stuff developed to absorb moisture in disposable diapers. Check with your cable supplier to see if they offer it.

- **Fire Code Ratings:**

**Every cable installed indoors must meet fire codes. That means the jacket must be rated for fire resistance, with ratings for general use, riser (a vertical cable feeds flames more than horizontal) and plenum (for installation in air-handling areas. Most indoor cables use PVC (polyvinyl chloride) jacketing for fire retardance. All premises cables must carry identification and flammability ratings per the NEC (National Electrical Code) paragraph 770. These ratings are:**

<b>NEC Rating:</b>	<b>Description:</b>
<b>OFN</b>	<b>optical fiber non-conductive</b>
<b>OFC</b>	<b>optical fiber conductive</b>
<b>OFNG or OFCG</b>	<b>general purpose</b>
<b>OFNR or OFCR</b>	<b>riser rated cable for vertical runs</b>
<b>OFNP or OFCP</b>	<b>plenum rated cables for use in air-handling plenums</b>
<b>OFN-LS</b>	<b>low smoke density</b>

**Cables without markings should never be installed as they will not pass inspections! Outdoor cables are not fire-rated and can only be used up to 50 feet (15,25 meters) indoors. If you need to bring an outdoor cable indoors, consider a double-jacketed cable with PE jacket over a PVC UL-rated indoor jacket. Simply remove the outdoor jacket when you come indoors and you will not have to terminate at the entry point.**

## Choosing A Cable

With so much choice in cables, it is hard to find the right one. The table below summarizes the choices, applications and advantages of each.

<b>Cable Type:</b>	<b>Application:</b>	<b>Advantages:</b>
<b>Tight Buffer</b>	<b>Premises</b>	<b>Makes rugged patchcords</b>
<b>Distribution</b>	<b>Premises</b>	<b>Small size for lots of fibers, inexpensive</b>
<b>Breakout</b>	<b>Premises</b>	<b>Rugged, easy to terminate, no hardware needed</b>
<b>Loose Tube</b>	<b>Outside Plant</b>	<b>Rugged, gel or dry water-blocking</b>
<b>Armored</b>	<b>Outside Plant</b>	<b>Prevents rodent damage</b>
<b>Ribbon</b>	<b>Outside Plant</b>	<b>Highest fiber count for small size</b>



## **Pulling Fiber Optic Cable**

**Installation methods for both wire cables and optical fiber cables are similar. Fiber cable can be pulled with much greater force than copper wire if you pull it correctly. Just remember these rules:**

- Do not pull on the fibers, pull on the strength members only! The cable manufacturer gives you the perfect solution to pulling the cables, they install special strength members, usually Kevlar aramid yarn or a fiberglass rod to pull on. Use it! Any other method may put stress on the fibers and harm them. Most cables cannot be pulled by the jacket. Do not pull on the jacket unless it is specifically approved by the cable manufacturers and you use an approved cable grip.**
- Do not exceed the maximum pulling load rating. On long runs, use proper lubricants and make sure they are compatible with the cable jacket. On really long runs, pull from the middle out to both ends. If possible, use an automated puller with tension control or at least a breakaway pulling eye.**
- Do not exceed the cable bend radius. Fiber is stronger than steel when you pull it straight, but it breaks easily when bent too tightly. These will harm the fibers, maybe immediately, maybe not for a few years, but you will harm them and the cable must be removed and thrown away!**
- Do not twist the cable. Putting a twist in the cable can stress the fibers too. Always roll the cable off the spool instead of spinning it off the spool end.**

**This will put a twist in the cable for every turn on the spool! If you are laying cable out for a long pull, use a "figure 8" on the ground to prevent twisting (the figure 8 puts a half twist in on one side of the 8 and takes it out on the other, preventing twists.) And always use a swivel pulling eye because pulling tension will cause twisting forces on the cable.**

- **Check the length. Make sure the cable is long enough for the run. It's not easy or cheap to splice fiber and it needs special protection. Try to make it in one pull, possible up to about 3,22-4,83 kilometres (2-3 miles).**

- **Conduit and Innerduct:**

**Outside plant cables are either installed in conduit or innerduct or direct buried, depending on the cable type. Building cables can be installed directly, but you might consider putting them inside plenum-rated innerduct. This innerduct is bright orange and will provide a good way to identify fiber optic cable and protect it from damage, generally a result of someone cutting it by mistake! The innerduct can speed installation and maybe even cut costs. It can be installed quickly by unskilled labor, then the fiber cable can be pulled through in seconds. You can even get the innerduct with pulling tape already installed.**

## **Cable Plant Hardware - fitting the pieces of the puzzle together!**

**These various enclosures, cabinets, racks and panels are used to protect and organize splice and termination points. The network designer should know the type of network, support systems, the routes to be taken. Then the connection/splice locations can be determined and the hardware planned.**

**There are lots of rules to follow, of course (the EIA/TIA 569 has something to say about all this).**

**Here are some examples of fiber optic hardware:**

- **Breakout kits:**  
They allow you to separate and protect individual fibers in a loose tube cable so it can be terminated.
- **Splice enclosures:**  
For long cable runs outside, the point where cables are spliced, sealed up and buried in the ground, put in a vault of some kind or hung off a pole.
- **Splice panels:**  
Connect individual fibers from cables to pigtails.
- **Patch panels:**  
Provides a centralized location for patching fibers, testing, monitoring and restoring cables.
- **Racks and cabinets:**  
Enclosures for patch panels and splice panels. Usually these also include cable management -

**without this the cables start looking like spaghetti flying everywhere in a short time!**

**There are tons of hardware and tons of manufacturers who make them. Be sure to choose panels that have the connections behind locked doors, since the biggest problem we see is connectors broken by people messing around in communications closets! Fiber doesn't need maintenance or inspection. Lock 'em up and only unlock it when you have to move something!**

# ***Terminations***

## **Termination**

**We terminate fiber optic cable two ways - with connectors that can mate two fibers to create a temporary joint and/or connect the fiber to a piece of network gear or with splices which create a permanent joint between the two fibers. These terminations must be of the right style, installed in a manner that makes them have little light loss and protected against dirt or damage in use.**

**No area of fiber optics has been given greater attention than termination. Manufacturers have come up with over 80 styles of connectors and about a dozen ways to install them. There are two types of splices and many ways of implementing the splice. Fortunately for me and you, only a few types are used most applications.**

**Different connectors and splice termination procedures are used for singlemode and multimode connectors, so make sure you know what the fiber will be before you specify connectors or splices!**

## Connectors

**We'll start our section on termination by considering connectors. Since fiber optic technology was introduced in the late 70s, numerous connector styles have been developed. Each new design was meant to offer better performance (less light loss and back reflection), easier and/or termination and lower cost. Of course, the marketplace determines which connectors are ultimately successful.**

# Connector and Splice Loss Mechanisms

- **Connector and splice loss is caused by a number of factors. Loss is minimized when the two fiber cores are identical and perfectly aligned, the connectors or splices are properly finished and no dirt is present. Only the light that is coupled into the receiving fiber's core will propagate, so all the rest of the light becomes the connector or splice loss.**

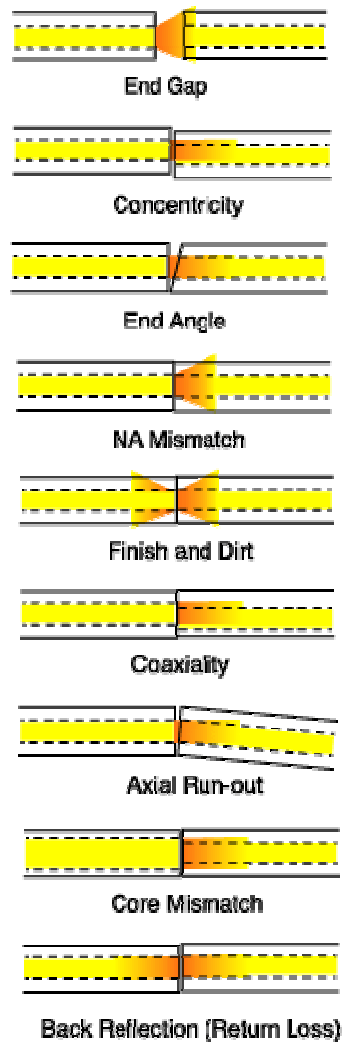



- **End gaps cause two problems, insertion loss and return loss. The emerging cone of light from the connector will spill over the core of the receiving fiber and be lost. In addition, the air gap between the fibers causes a reflection when the light encounters the change in refractive index from the glass fiber to the air in the gap. This reflection (called fresnel reflection) amounts to about 5% in typical flat polished connectors, and means that no connector with an air gap can have less than 0.3 dB loss. This reflection is also referred to as back reflection or optical return loss, which can be a problem in laser based systems. Connectors use a number of polishing techniques to insure physical contact of the fiber ends to minimize back reflection. On mechanical splices, it is possible to reduce back reflection by using non-perpendicular cleaves, which cause back reflections to be absorbed in the cladding of the fiber.**
- **The end finish of the fiber must be properly polished to minimize loss. A rough surface will scatter light and dirt can scatter and absorb light. Since the optical fiber is so small, typical airborne dirt can be a major source of loss. Whenever connectors are not terminated, they should be covered to protect the end of the ferrule from dirt. One should never touch the end of the ferrule, since the oils on one's skin causes the fiber to attract dirt. Before connection and testing, it is**

**advisable to clean connectors with lint-free wipes moistened with isopropyl alcohol.**

- **Two sources of loss are directional; numerical aperture (NA) and core diameter. Differences in these two will create connections that have different losses depending on the direction of light propagation. Light from a fiber with a larger NA will be more sensitive to angularity and end gap, so transmission from a fiber of larger NA to one of smaller NA will be higher loss than the reverse. Likewise, light from a larger fiber will have high loss coupled to a fiber of smaller diameter, while one can couple a small diameter fiber to a large diameter fiber with minimal loss, since it is much less sensitive to end gap or lateral offset.**
- **These fiber mismatches occur for two reasons. The occasional need to interconnect two dissimilar fibers and production variances in fibers of the same nominal dimensions. With two multimode fibers in usage today and two others which have been used occasionally in the past and several types of singlemode fiber in use, it is possible to sometimes have to connect dissimilar fibers or use systems designed for one fiber on another. Some system manufacturers provide guidelines on using various fibers, some don't. If you connect a smaller fiber to a larger one, the coupling losses will be minimal, often only the fresnel loss (about 0.3 dB). But connecting larger fibers to smaller ones results in substantial losses, not only due to the smaller**

**cores size, but also the smaller NA of most small core fibers.**

## Guide to Fiber Optic Connectors

Check out the "spotters guide" below and you will see the most common fiber optic connectors. (All the photos are to the same scale, so you can get an idea of the relative size of these connectors.)

- **ST is the most popular connector for multimode networks, like most buildings and campuses. It has a bayonet mount and a long cylindrical ferrule to hold the fiber. Most ferrules are ceramic, but some are metal or plastic. And because they are spring-loaded, you have to make sure they are seated properly. If you have high loss, reconnect them to see if it makes a difference.**



- **FC/PC has been one of the most popular singlemode connectors for many years. It screws on firmly, but make sure you have the key aligned in the slot properly before tightening. It's being replaced by SCs and LCs.**





- **SC is a snap-in connector that is widely used in singlemode systems for its excellent performance. It's a snap-in connector that latches with a simple push-pull motion. It is also available in a duplex configuration.**



- Besides the SC Duplex, you may occasionally see the FDDI and ESCON duplex connectors which mate to their specific networks. They are generally used to connect to the equipment from a wall outlet, but the rest of the network will have ST or SC connectors.

Below are some of the new Small Form Factor (SFF) connectors:

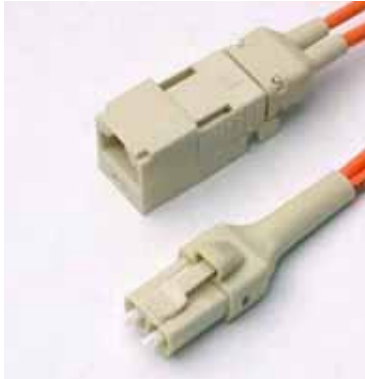
- LC is a new connector that uses a 1.25 mm (0.05 inch) ferrule, half the size of the ST. Otherwise, it's a standard ceramic ferrule connector, easily terminated with any adhesive. Good performance, highly favored for singlemode. 
- MT-RJ is a duplex connector with both fibers in a single polymer ferrule. It uses pins for alignment and has male and female versions. Multimode only, field terminated only by prepolished/splice method. 
- Opti-Jack is a neat, rugged duplex connector cleverly designed around two ST-type ferrules in a package the size of a RJ-45. It has male and female (plug and jack) versions. 

- **Volition** is a slick, inexpensive duplex connector that uses no ferrule at all. It aligns fibers in a V-groove like a splice. Plug and jack versions, but field terminate jacks only.



- **E2000/LX-5** is like a LC but with a shutter over the end of the fiber.



- **MU** looks a miniature SC with a 1.25 mm (0.05 inch) ferrule. It's more popular in Japan.



- **MT** is a 12 fiber connector for ribbon cable. It's main use is for preterminated cable assemblies.



**The ST/SC/FC/FDDI/ESON connectors have the same ferrule size - 2.5 mm or about 0.1 inch - so they can be mixed and matched to each other using hybrid mating adapters. This makes it convenient to test, since you can have a set of multimode reference test cables with ST connectors and adapt to all these connectors. Likewise, the LC, MU and E2000/LX-5**

**use the same ferrule but cross-mating adapters are not easy to find.**

## Connector Types

- **The ST is still the most popular multimode connector because it is cheap and easy to install.**
- **The SC connector was specified as a standard by the old EIA/TIA 568A specification, but its higher cost and difficulty of installation (until recently) has limited its popularity. However, newer SCs are much better in both cost and installation ease, so it has been growing in use.**
- **The duplex FDDI, ESCON and SC connectors are used for patchcords to equipment and can be mated to ST or SC connectors at wall outlets.**
- **Singlemode networks use FC or SC connectors in about the same proportion as ST and SC in multimode installations. There are some D4s out there too.**
- **EIA/TIA 568 B allows any fiber optic connector as long as it has a FOCIS (Fiber Optic Connector Intermateability Standard) document behind it. This opened the way to the use of several new connectors, which we call the "Small Form Factor" (SFF) connectors, including AT&T LC, the MT-RJ, the "Opti-Jack," Volition, the E2000/LX-5 and MU. The LC has been particularly successful in the US.**



## Connector Ferrule Shapes & Polishes

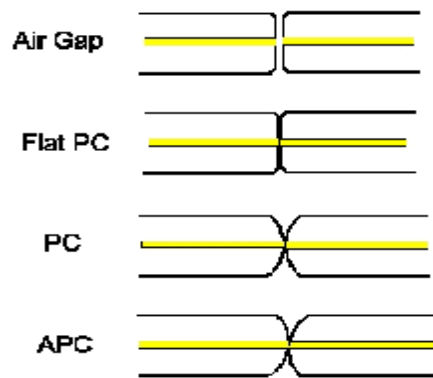

Fiber optic connectors can have several different ferrule shapes or finishes, usually referred to as polishes. early connectors, because they did not have keyed ferrules and could rotate in mating adapters, always had an air gap between the connectors to prevent them rotating and grinding scratches into the ends of the fibers.

Beginning with the ST and FC which had keyed ferrules, the connectors were designed to contact tightly, what we now call physical contact (PC) connectors. Reducing the air gap reduced the loss and back reflection (very important to laser-based singlemode systems ), since light has a loss of about 5% ( $\sim 0.25$  dB) at each air gap and light is reflected back up the fiber. While air gap connectors usually had losses of 0.5 dB or more and return loss of 20 dB, PC connectors had typical losses of 0.3 dB and a return loss of 30 to 40 dB.

Soon thereafter, it was determined that making the connector ferrules convex would produce an even better connection. The convex ferrule guaranteed the

**fiber cores were in contact. Losses were under 0.3dB and return loss 40 dB or better. The final solution for singlemode systems extremely sensitive to reflections, like CATV or high bitrate telco links, was to angle the end of the ferrule 8 degrees to create what we call an APC or angled PC connector. Then any reflected light is at an angle that is absorbed in the cladding of the fiber.**

## Termination Procedures

- **Whatever you do, follow the manufacturer's termination instructions closely.**
- **Multimode connectors are usually installed in the field on the cables after pulling, while singlemode connectors are usually installed by splicing a factory-made "pigtail" onto the fiber. That is because the tolerances on singlemode terminations are much tighter and the polishing processes are more critical. You can install singlemode connectors in the field for low speed data networks, but you may not be able to get losses lower than 1 dB!**
- **Cables can be pulled with connectors already on them if, and a big if, you can deal with these two problems: First, the length must be precise. Too short and you have to pull another longer one (its not cost effective to splice), too long and you waste money and have to store the extra cable length. Secondly, the connectors must be protected. Some cable and connector manufacturers offer protective sleeves to cover the connectors, but you must still be much more careful in pulling cables. You might consider terminating one end and pulling the unterminated end to not risk the connectors.**
- **There is a growing movement to install preterminated systems but with the MT 12 multifiber connector. It's tiny not much bigger than a ST or SC, but has up to 12 fibers. Manufactures sell multifiber cables with MTs on them that**

connect to preterminated patch panels with STs or SCs. Works well if you have a good designer and can live with the higher loss (~ 1 dB) typical of these connectors.

- **Multimode Terminations:** Several different types of terminations are available for multimode fibers. Each version has its advantages and disadvantages, so learning more about how each works helps decide which one to use.
- **A note on adhesives:** Most connectors use epoxies or other adhesives to hold the fiber in the connector. Use only the specified epoxy, as the fiber to ferrule bond is critical for low loss and long term reliability! We've seen people use hardware store epoxies, Crazy Glue, you name it! And they regretted doing it.
- **Epoxy/Polish:** Most connectors are the simple "epoxy/polish" type where the fiber is glued into the connector with epoxy and the end polished with special polishing film. These provide the most reliable connection, lowest losses (less than 0.5 dB) and lowest costs, especially if you are doing a lot of connectors. The epoxy can be allowed to set overnight or cured in an inexpensive oven. A "heat gun" should never be used to try to cure the epoxy faster as the uneven heat may not cure all the epoxy or may overheat some of it which will prevent it ever curing!



- **"Hot Melt":** Is a connector that already has the epoxy (actually a heat set glue) inside the connector. You strip the cable, insert it in the connector, crimp it, and put it in a special oven. In a few minutes, the glue is melted, so you remove the connector, let it cool and it is ready to polish. Fast and easy, low loss, but not as cheap as the epoxy type, it has become the favorite of lots of contractors who install relatively small quantities of connectors.
- **Anaerobic Adhesives:** These connectors use a quick setting adhesive to replace the epoxy. They work well if your technique is good, but often they do not have the wide temperature range of epoxies, so only use them indoors. A lot of installers are using Loctite 648, with or without the accelerator solution, that is neat and easy to use.
- **Crimp/Polish:** Rather than glue the fiber in the connector, these connectors use a crimp on the fiber to hold it in. Early types offered "iffy" performance, but today they are pretty good, if you practice a lot. Expect to trade higher losses for the faster termination speed. And they are more costly than epoxy polish types. A good choice if you only install small quantities and your customer will accept them.
- **Prepolished/splice:** Some manufacturers offer connectors that have a short stub fiber already epoxied into the ferrule and polished perfectly, so you just cleave a fiber and insert it like a splice.

**(See next section for splicing info.) While it sound like a great idea, it has several downsides. First it is very costly, five to ten times as much as an epoxy polish type. Second, you have to make a good cleave to make them low loss, and that is not as easy as you might think. Third, even if you do everything correctly, you loss will be higher, because you have a connector loss plus two splice losses at every connection! The best way to terminate them is to monitor the loss with a visual fault locator and "tweak" them.**

## Hints for doing field terminations

Here are a few things to remember when you are terminating connectors in the field. Following these guidelines will save you time, money and frustration.

- Choose the connector carefully and clear it with the customer if it is anything other than an epoxy/polish type. Some customers have strong opinions on the types or brands of connectors used in their job. Find out first, not later!
- Never, never, NEVER take a new connector in the field until you have installed enough of them in the office that you can put them on in your sleep. The field is no place to experiment or learn! It'll cost you big time!
- Have the right tools for the job. Make sure you have the proper tools and they are in good shape before you head out for the job. This includes all the termination tools, cable tools and test equipment. Do you know your test cables are good? Without that, you will test good terminations as bad every time. More and more installers are owning their own tools like auto mechanics, saying that is the only way to make sure the tools are properly cared for.
- Dust and dirt are your enemies. It's very hard to terminate or splice in a dusty place. Try to work in the cleanest possible location. Use lint-free wipes (not cotton swaps or rags made from old T-shirts!) to clean every connector before connecting or

**testing it. Don't work under heating vents, as they are blowing dirt down on you continuously.**

- **Don't overpolish. Contrary to common sense, too much polishing is just as bad as too little. The ceramic ferrule in most of today's connector is much harder than the glass fiber. Polish too much and you create a concave fiber surface, increasing the loss. A few swipes is all it takes.**
- **Remember singlemode fiber requires different connectors and polishing techniques. Most SM fiber is terminated by splicing on a preterminated pigtail, but you can put SM connectors on in the field if you know what you are doing. Expect much higher loss, approaching 1 dB and high back reflections, so don't try it for anything but data networks, not telco or CATV.**
- **Change polishing film regularly. Polishing builds up residue and dirt on the film that can cause problems after too many connectors and cause poor end finish. Check the manufacturers' specs.**
- **Put covers on connectors and patch panels when not in use. Keep them covered to keep them clean.**
- **Inspect and test, then document. It is very hard to troubleshoot cables when you don't know how long they are, where they go or how they tested originally! So keep good records, smart users require it and expect to pay extra for good records.**



# Splicing

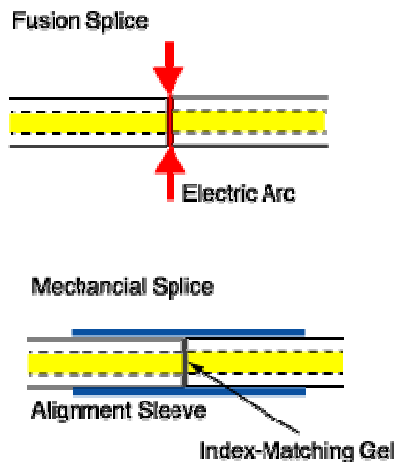

- **Splicing is only needed if the cable runs are too long for one straight pull or you need to mix a number of different types of cables (like bringing a 48 fiber cable in and splicing it to six 8 fiber cables - could you have used a breakout cable instead?) And of course, we use splices for restoration, after the number one problem of outside plant cables, a dig-up and cut of a buried cable, usually referred to as "backhoe fade" for obvious reasons!**
- **Splices are "permanent" connections between two fibers. There are two types of splices, fusion and mechanical, and the choice is usually based on cost or location. Most splicing is on long haul outside plant SM cables, not multimode LANs, so if you do outside plant SM jobs, you will want to learn how to fusion splice. If you do mostly MM LANs, you may never see a splice.**
- **Fusion Splices are made by "welding" the two fibers together usually by an electric arc. Obviously, you don't do that in an explosive**

atmosphere (at least not more than once!), so fusion splicing is usually done above ground in a truck or trailer set up for the purpose. Good fusion splicers cost €12,000 to €20,000, but the splices only cost a few dollars each. Today's singlemode fusion splicers are automated and you have a hard time making a bad splice. The biggest application is singlemode fibers in outside plant installations.

- **Mechanical Splices** are alignment gadgets that hold the ends of two fibers together with some index matching gel or glue between them. There are a number of types of mechanical splices, like little glass tubes or V-shaped metal clamps. The tools to make mechanical splices are cheap, but the splices themselves are expensive. Many mechanical splices are used for restoration, but they can work well with both singlemode and multimode fiber, with practice.



## **Which Splice ?**

- **If cost is the issue, we've given you the clues to make a choice: fusion is expensive equipment and cheap splices, while mechanical is cheap equipment and expensive splices. So if you make a lot of splices (like thousands in an big telco or CATV network) use fusion splices. If you need just a few, use mechanical splices.**
- **Fusion splices give very low back reflections and are preferred for singlemode high speed digital or CATV networks. However, they don't work too well on multimode splices, so mechanical splices are preferred for MM, unless it is an underwater or aerial application, where the greater reliability of the fusion splice is preferred.**

# ***Networks***

## Fiber Optic Networks

- In the telcos, singlemode fiber is used to connect long distance switches, central offices and SLCs (subscriber loop carriers, small switches in pedestals in subdivisions or office parks or in the basement of a larger building). Practically every telco's network is now fiber optics except the connection to the home. Fiber to the home (FTTH) is now cost effective - especially since most homes want the high speed services that would justify fiber optics. Look for FTTH first in new home construction.
- CATV companies "overbuild" with fiber. They lash fiber cable onto the aerial "hardline" coax used for the rest of the network or pull it in the same conduit underground. The fiber allows them to break their network into smaller service areas that prevent large numbers of customers from being affected in an outage, making for better service and customer relations. The fiber also gives them a return path which they use for Internet and telephone connections, increasing their revenue potential.
- LANs (local area networks) use fiber optics primarily in the backbone but increasingly to the desk. The LAN backbone often needs longer distance than copper cable (Cat 5/5e/6) can provide and of course, the fiber offers higher bandwidth for future expansion. Most large corporate LANs use fiber backbones with copper wire to the desktop.

**Fiber to the desk can be cost effective if properly designed.**

- **Lots of other networks use fiber. CCTV is often on fiber for it's distance capability. Industrial plants use lots of fiber for distance and noise immunity. Utilities use it for network management, liking its immunity to noise also. The military uses it because it's hard to tap or jam. Airplanes use it for that reason too, but also like the lighter weight of fiber.**

# Designing Cable Networks

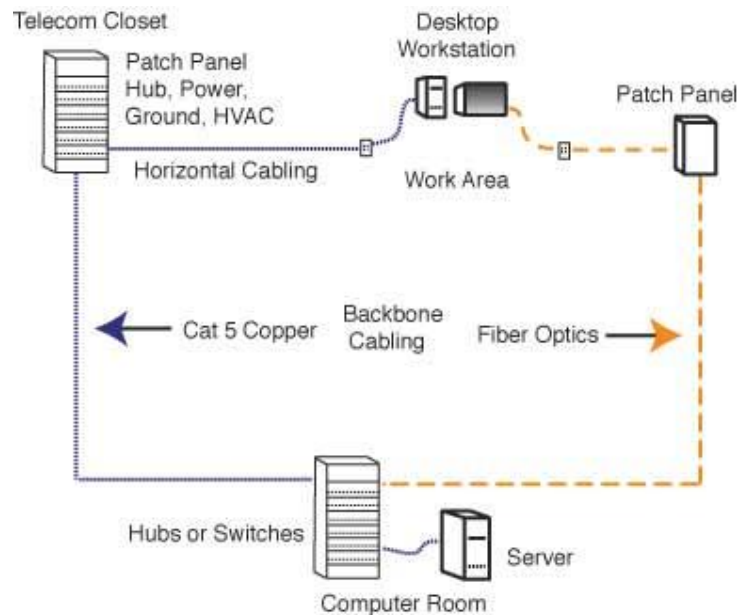

- **I guess this is too big a topic for an overview! But we'll pass along some hints to make life easier. Know the "standards" but use common sense in designing the installation. Don't cut corners which may affect performance or reliability. Consider what are the possible problems and work around or prevent them. There ain't no substitute for common sense here!**
- **Fiber's extra distance capability makes it possible to do things not possible with copper wire. For example, you can install all the electronics for a network in one communications closet for a building and run straight to the desktop with fiber. With copper, you can only go about 90 meters (less than 300 feet), so you need to keep the electronics close to the desk. With fiber, you only need passive patch panels locally to allow for moves. Upgrades**

are easy, since the fiber is only loading at today's network speed!

## Is Copper Really Cheaper Than Fiber?

- When it comes to costs, fiber optics is always assumed to be much more expensive than copper cabling. Whatever you look at - cable, terminations or networking electronics - fiber costs more, although as copper gets faster (e.g. Cat 6) it gets more expensive, almost as much as fiber. So isn't it obvious that fiber networks are more expensive than copper? Maybe not! There is more to consider in making the decision.

## Why Use Fiber?

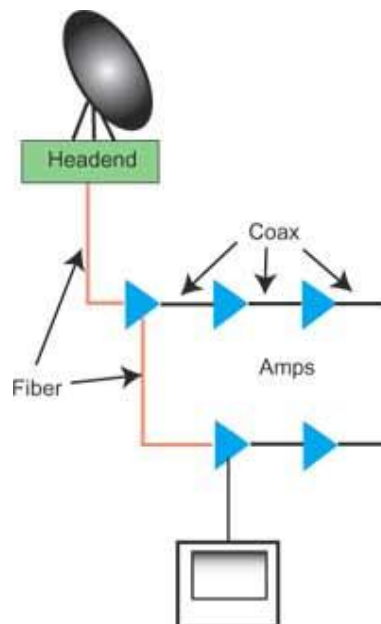

- If fiber is more expensive, why have all the telephone networks been converted to fiber? And why are all the CATV systems converting to fiber



**too? Are their networks that different? Is there something they know we don't?**

- Telcos use fiber to connect all their central offices and long distance switches because it has thousands of times the bandwidth of copper wire and can carry signals hundreds of times further before needing a repeater. The CATV companies use fiber because it give them greater reliability and the opportunity to offer new services, like phone service and Internet connections.**
- Both telcos and CATV operators use fiber for economic reasons, but their cost justification requires adopting new network architectures to take advantage of fiber's strengths. A properly designed premises cabling network can also be less expensive when done in fiber instead of copper. There are several good examples of fiber being less expensive, so lets examine them.**

## **Industrial Networks**

- **In an industrial environment, electromagnetic interference (EMI) is often a big problem. Motors, relays, welders and other industrial equipment generate a tremendous amount of electrical noise that can cause major problems with copper cabling, especially unshielded cable like Cat 5. In order to run copper cable in an industrial environment, it is often necessary to pull it through conduit to provide adequate shielding.**
- **With fiber optics, you have complete immunity to EMI. You only need to choose a cable type that is rugged enough for the installation, with breakout cable being a good choice for it's heavy-duty construction. The fiber optic cable can be installed easily from point to point, passing right next to major sources of EMI with no effect. Conversion from copper networks is easy with media converters, gadgets that convert most types of systems to fiber optics. Even with the cost of the media converters, the fiber optic network will be less than copper run in conduit.**

## Long Cable Runs

- **Most networks are designed around structured cabling installed per EIA/TIA 568 standards. This standard calls for 90 meters (295 feet) of permanently installed unshielded twisted pair (UTP) cable and 10 meters (33 feet) of patchcords. But suppose you need to connect two buildings or more? The distance often exceeds the 90 meters (295 feet) by the time you include the runs between the buildings plus what you need inside each building.**
- **By the time you buy special aerial or underground waterproof copper cable and repeaters, you will usually spend more than if you bought some outside plant fiber optic cable and a couple of inexpensive media converters. It's guaranteed cheaper if you go more than two links (180 meters/ 590 feet)**

## Centralized Fiber LANs

- When most contractors and end users look at fiber optics versus Cat 5e cabling for a LAN, they compare the same old copper LAN with fiber directly replacing the copper links. The fiber optic cable is a bit more expensive than Cat 5e and terminations are a little more too, but the big difference is the electronics which are €160 or more per link extra for fiber.
- However, the real difference comes if you use a centralized fiber optic network - shown on the right of the diagram above. Since fiber does not have the 90 meter (295 feet) distance limitation of UTP cable, you can place all electronics in one location in or near the computer room. The telecom closet is only used for passive connection of backbone fiber optic cables, so no power, UPS, ground or air conditioning is needed. These auxiliary services, necessary with Cat 5 hubs, cost a tremendous amount of money in each closet.
- In addition, having all the fiber optic hubs in one location means better utilization of the hardware, with fewer unused ports. Since ports in modular hubs must be added in modules of 8 or 16, it's not uncommon with a hub in a telecom closet to have many of the ports in a module empty . With a centralized fiber system, you can add modules more efficiently as you are supporting many more desktop locations but need never have more than a one module with open ports.

## High Speed Networking

**It was over a year after Gigabit Ethernet (GbE) became available on fiber optics that it finally become available on Cat 5e. It took another couple of years before GbE on copper became significantly less expensive. In order to get GbE to work over Cat 5e, the electronics must be very complicated, and consequently as expensive as fiber. A newer version is in the wings, awaiting a Cat 6 standard, but that means the version running over Cat 5e will be obsolete before it even gets started! Finally, we went to a major distributor's seminar on advanced cabling recently and the copper marketing guy told us to go fiber for GbE.**

## **Bottom Line**

**So when it comes to costs, looking at the cabling component costs may not be a good way to analyze total network costs. Consider the total system and you may find fiber looks a lot more attractive.**

# ***Estimating and Bidding***

## **Estimating and Bidding**

- **Estimating is necessary to figure out what the job will cost you. First of all you'll need to set up a simple chart of all the details: the items you will need to purchase (i.e. cable, connectors, etc) and their costs. You will also need to add labor cost.**
- **Do your homework - be sure to have an accurate idea of how long it takes for each step of the installation.**
- **For instance, when dealing with connectors, if a manufacturer says you can terminate his connector in 3 minutes, test it for yourself in the office before you go to the site. Not only do you want to know how long it will take, but also how many good ones you get. Are you working on a "tried and true" method such as using epoxy or anaerobic adhesive with ST or SC connectors where installation estimates are well documented or a new system such as MTRJ connectors or a "cleave and leave" connector you have never done before? Big difference! The newer or more specialized the connector or the installation process, the more unpredictable the timing can be. This rule can apply to all the materials and equipment you will be using. Try to identify who will answer your questions from the companies who sold the connectors, cable and the other materials before you go to the job site. This will help avoid serious delays if you run into trouble.**



- **Consider yield. You will never get every connector or splice right the first time. If you get 90% good in the field, you are a hero! Magazines periodically publish articles about the yield of various connectors tested in the field - the yield for certain connectors can be as low as 30%!**
- **Be sure to visit the job site - you have to see for yourself what the job looks like. Get as much information as you can - walk the route carefully and note things such as what other cables are there and will they have to be removed, the condition of the building and any potential problems with moisture or excessive heat or cold, any inconsistencies from the architectural drawings, what other work is being done at the same time and how it will effect what you're doing, can you easily get your equipment where it needs to be. Bring a camera if the customer will let you - take lots of pictures! Trust us, we have seen every mistake made and more! Double - then triple check everything. You won't regret it.**
- **Talk to the customer - be sure to understand exactly what will be required of you. You must know what types of cable, connectors, splices, hardware, etc. the customer wants (including brands - if specified). Does the customer want employees to be trained? Get all the details on this up front also. Don't be afraid to suggest alternatives that will save him (and you) money. Research the customer - how long have they been**

**in business? Do they pay their contractors on time? Ask around - if there is a problem, it will probably surface.**

- **Read the specifications carefully - if you see something that doesn't make sense (like the all too common one of asking for OTDR test data on short LAN cable runs), tell the customer your concerns before you bid. Don't bid blindly.**
- **Once you have gathered all your information, you will need to bring your math skills into play and create a document (usually a spreadsheet) that allows you to transfer all this information into a "map" of the job that you and your workers can follow.**

## **Bidding**

**Bidding is closely related to estimating, but adds in the profit margin you need to stay in business - don't forget that! If you bid accurately, you will never regret losing a job to a lower bidder, because you know that the winning bid is close to or losing money and that is not the goal of running a business. Bid accurately and you will stay in business!**

## **Documentation**

**Knowing where every cable, connector, splice, patch panel, etc goes and the length of every cable is more than helpful. It can help you in bidding, buying, installation, testing, and restoration. After installation, keep test data to refer back to when you have problems.**

**Smart installers understand the value of documentation and understand it can lead to higher bids, but good documentation pays for itself. Smart users understand it too and are willing to pay for good documentation.**

## **Estimating Software**

**Today you can get several great programs that automate the estimation process. They can access databases of costs, aggregate components and do lots more to simplify the process. Evaluate all these products - a contractors trade show is a good place to start looking at them - to see if they meet your needs.**

# ***Testing***

## Testing

- **After the cables are installed and terminated, it's time for testing. For every fiber optic cable plant, you will need to test for continuity, end-to-end loss and then troubleshoot the problems. If it's a long outside plant cable with intermediate splices, you will probably want to verify the individual splices with an OTDR also, since that's the only way to make sure that each one is good. If you are the network user, you will also be interested in testing power, as power is the measurement that tells you whether the system is operating properly.**
- **You'll need a few special tools and instruments to test fiber optics. See Jargon in the beginning of this training to see a description of each instrument.**

## **Getting started**

**Even if you're an experienced installer, make sure you remember these things.**

### **5. Have the right tools and test equipment for the job...**

**You will need:**

- **Source and power meter, optical loss test set or test kit with proper equipment adapters for the cable plant you are testing.**
- **Reference test cables that match the cables to be tested and mating adapters, including hybrids if needed**
- **Fiber Tracer or Visual Fault Locator**
- **Cleaning materials - lint free cleaning wipes and pure alcohol**
- **OTDR and launch cable for outside plant jobs**

### **6. Know how to use your test equipment**

**Before you start, get together all your tools and make sure they are all working properly and you and your installers know how to use them. It's hard to get the job done when you have to call the manufacturer from the job site on your cell phone to ask for help. Try all your equipment in the office before you take it into the field. Use it to test every one of your reference test jumper cables in both directions using the single-ended loss test to make sure they are all good. If your power meter has internal memory to record data be sure you know how to use this also. You can often customize these**



**reports to your specific needs - figure all this out before you go it the field - it could save you time and on installations, time is money!**

## **7. Know the network you're testing...**

**This is an important part of the documentation process we discussed earlier. Make sure you have cable layouts for every fiber you have to test. Prepare a spreadsheet of all the cables and fibers before you go in the field and print a copy for recording your test data. You may record all your test data either by hand or if your meter has a memory feature, it will keep test results in on-board memory that can be printed or transferred to a computer when you return to the office.**

**A note on using a fiber optic source eye safety...**

**Fiber optic sources, including test equipment, are generally too low in power to cause any eye damage, but it's still a good idea to check connectors with a power meter before looking into it. Some telco DWDM and CATV systems have very high power and they could be harmful, so better safe than sorry.**

**Fiber optic testing includes three basic tests that we will cover separately:**

- Visual inspection for continuity or connector checking**
- Loss testing**
- Network Testing**

## Visual Tracing

- **Continuity checking makes certain the fibers are not broken and to trace a path of a fiber from one end to another through many connections. Use a visible light "fiber optic tracer" or "pocket visual fault locator". It looks like a flashlight or a pen-like instrument with a lightbulb or LED source that mates to a fiber optic connector. Attach a cable to test to the visual tracer and look at the other end to see the light transmitted through the core of the fiber. If there is no light at the end, go back to intermediate connections to find the bad section of the cable.**
- **A good example of how it can save time and money is testing fiber on a reel before you pull it to make sure it hasn't been damaged during shipment. Look for visible signs of damage (like cracked or broken reels, kinks in the cable, etc.). For testing, visual tracers help also identify the next fiber to be tested for loss with the test kit. When connecting cables at patch panels, use the visual tracer to make sure each connection is the right two fibers! And to make certain the proper fibers are connected to the transmitter and receiver, use the visual tracer in place of the transmitter and your eye instead of the receiver (remember that fiber optic links work in the infrared so you can't see anything anyway.)**

## **Visual Fault Location**

- **A higher power version of the tracer uses a laser that can also find faults. The red laser light is powerful enough to show breaks in fibers or high loss connectors. You can actually see the loss of the bright red light even through many yellow or orange simplex cable jackets except black or gray jackets. You can also use this gadget to optimize mechanical splices or prepolished-splice type fiber optic connectors. In fact- don't even think of doing one of those connectors without one no other method will assure you of high yield with them.**

## **Visual Connector Inspection**

- **Fiber optic microscopes are used to inspect connectors to check the quality of the termination procedure and diagnose problems. A well made connector will have a smooth , polished, scratch free finish and the fiber will not show any signs of cracks, chips or areas where the fiber is either protruding from the end of the ferrule or pulling back into it.**
- **The magnification for viewing connectors can be 30 to 400 power but it is best to use a medium magnification. The best microscopes allow you to inspect the connector from several angles, either by tilting the connector or having angle illumination to get the best picture of what's going on. Check to make sure the microscope has an easy-to-use**

**adapter to attach the connectors of interest to the microscope.**

- **And remember to check that no power is present in the cable before you look at it in a microscope protect your eyes!**
- **Optical Power - Power or Loss? ("Absolute" vs. "Relative")**
- **Practically every measurement in fiber optics refers to optical power. The power output of a transmitter or the input to receiver are "absolute" optical power measurements, that is, you measure the actual value of the power. Loss is a "relative" power measurement, the difference between the power coupled into a component like a cable or a connector and the power that is transmitted through it. This difference is what we call optical loss and defines the performance of a cable, connector, splice, etc.**

### **Measuring power**

- **Power in a fiber optic system is like voltage in an electrical circuit - it's what makes things happen! It's important to have enough power, but not too much. Too little power and the receiver may not be able to distinguish the signal from noise; too much power overloads the receiver and causes errors too.**
- **Measuring power requires only a power meter (most come with a screw-on adapter that matches the connector being tested) and a little help from the network electronics to turn on the transmitter.**

**Remember when you measure power, the meter must be set to the proper range (usually dBm, sometimes microwatts, but never "dB" that's a relative power range used only for testing loss!) and the proper wavelengths matching the source being used. Refer to the instructions that come with the test equipment for setup and measurement instructions (and don't wait until you get to the job site to try the equipment)!**

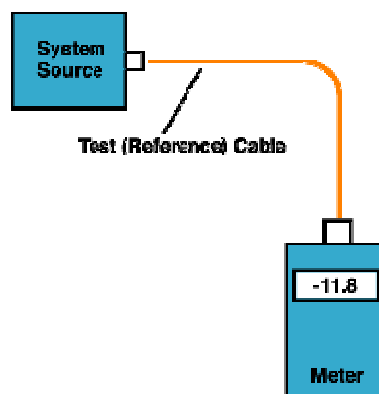

- **To measure power, attach the meter to the cable that has the output you want to measure. That can be at the receiver to measure receiver power, or to a reference test cable (tested and known to be good) that is attached to the transmitter, acting as the "source", to measure transmitter power. Turn on the transmitter/source and note the power the meter measures. Compare it to the specified power for the system and make sure it's enough power but not too much.**

## Testing loss

- **Loss testing is the difference between the power coupled into the cable at the transmitter end and what comes out at the receiver end. Testing for loss requires measuring the optical power lost in a cable (including connectors ,splices, etc.) with a fiber optic source and power meter by mating the cable being tested to known good reference cable.**
- **In addition to our power meter, we will need a test source. The test source should match the type of source (LED or laser) and wavelength (850, 1300, 1550 nm). Again, read the instructions that come with the unit carefully.**
- **We also need one or two reference cables, depending on the test we wish to perform. The accuracy of the measurement we make will depend on the quality of your reference cables. Always test your reference cables by the single ended method shown below to make sure they're good before you start testing other cables!**
- **Next we need to set our reference power for loss our "0 dB" value. Correct setting of the launch power is critical to making good loss measurements!**
- **Clean your connectors and set up your equipment like this:**
  - **Turn on the source and select the wavelength you want for the loss test.**

- Turn on the meter, select the "dBm" or "dB" range and select the wavelength you want for the loss test.
- Measure the power at the meter. This is your reference power level for all loss measurements. If your meter has a "zero" function, set this as your "0" reference.

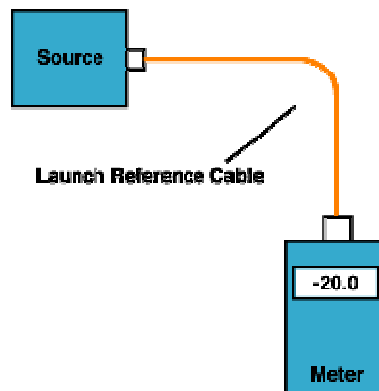

- Some reference books and manuals show setting the reference power for loss using both a launch and receive cable mated with a mating adapter. This method is acceptable for some tests, but will reduce the loss you measure by the amount of loss between your reference cables when you set your "0dB loss" reference. Also, if either the launch or receive cable is bad, setting the reference with both cables hides the fact. Then you could begin testing with bad launch cables making all your loss measurements wrong. EIA/TIA 568 calls for a single cable reference, while OFSTP-14 allows either method.

## Testing Loss

There are two methods that are used to measure loss, which we call "single-ended loss" and "double-ended loss". Single-ended loss uses only the launch cable, while double-ended loss uses a receive cable attached to the meter also.

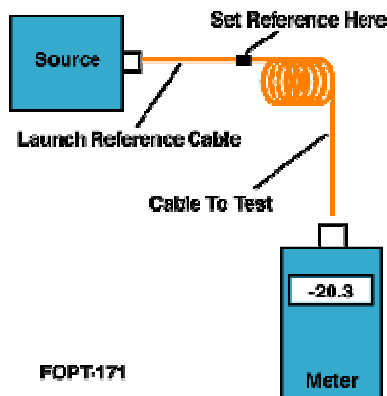

- **Single-ended loss is measured by mating the cable you want to test to the reference launch cable and measuring the power out the far end with the meter. When you do this you measure 1. the loss of the connector mated to the launch cable and 2. the loss of any fiber, splices or other connectors in the cable you are testing. This method is described in FOTP-171 and is shown in the drawing. Reverse the cable to test the connector on the other end.**

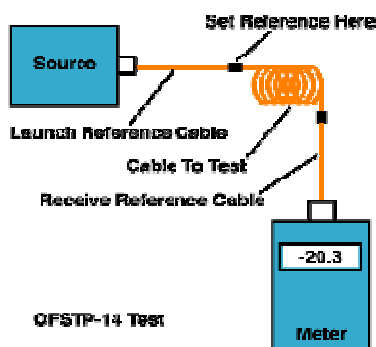



- **In a double-ended loss test, you attach the cable to test between two reference cables, one attached to the source and one to the meter. This way, you measure two connectors' losses, one on each end, plus the loss of all the cable or cables in between. This is the method specified in OFSTP-14, the test for loss in an installed cable plant.**

### **What Loss Should You Get When Testing Cables?**

**While it is difficult to generalize, here are some guidelines:**

- **For each connector, figure 0.5 dB loss (0.7 max).**
- **For each splice, figure 0.2 dB.**
- **For multimode fiber, the loss is about 3 dB per km for 850 nm sources, 1 dB per km for 1300 nm. This roughly translates into a loss of 0.1 dB per 100 feet (30,5 metres) for 850 nm, 0.1 dB per 300 feet (91,5 meters) for 1300 nm.**
- **For singlemode fiber, the loss is about 0.5 dB per km for 1300 nm sources, 0.4 dB per km for 1550 nm. This roughly translates into a loss of 0.1 dB per 600 feet (183 meters) for 1300 nm, 0.1 dB per 750 feet (229 metres) for 1550 nm.**

**So for the loss of a cable plant, calculate the approximate loss as:**

- **$(0.5 \text{ dB} \times \# \text{ connectors}) + (0.2 \text{ dB} \times \# \text{ splices})$   
+ fiber loss on the total length of cable**

## Troubleshooting Hints

- **If you have high loss in a cable, make sure to reverse it and test in the opposite direction using the single-ended method. Since the single ended test only tests the connector on one end, you can isolate a bad connector - it's the one at the launch cable end (mated to the launch cable) on the test when you measure high loss.**
- **High loss in the double ended test should be isolated by retesting single-ended and reversing the direction of test to see if the end connector is bad. If the loss is the same, you need to either test each segment separately to isolate the bad segment or, if it is long enough, use an OTDR.**
- **If you see no light through the cable (very high loss - only darkness when tested with your visual tracer), it's probably one of the connectors, and you have few options. The best one is to isolate the problem cable, cut the connector of one end (flip a coin to choose) and hope it was the bad one (well, you have a 50-50 chance!)**

## **OTDR Testing**

**As we mentioned earlier, OTDRs are always used on OSP cables to verify the loss of each splice. But they are also used as troubleshooting tools. Let's look at how an OTDR works and see how it can help testing and troubleshooting.**

## How OTDRs Work

- Unlike sources and power meters which measure the loss of the fiber optic cable plant directly, the OTDR works indirectly. The source and meter duplicate the transmitter and receiver of the fiber optic transmission link, so the measurement correlates well with actual system loss.
- The OTDR, however, uses backscattered light of the fiber to imply loss. The OTDR works like RADAR, sending a high power laser light pulse down the fiber and looking for return signals from backscattered light in the fiber itself or reflected light from connector or splice interfaces.
- At any point in time, the light the OTDR sees is the light scattered from the pulse passing through a region of the fiber. Only a small amount of light is scattered back toward the OTDR, but with sensitive receivers and signal averaging, it is possible to make measurements over relatively long distances. Since it is possible to calibrate the speed of the pulse as it passes down the fiber, the OTDR can measure time, calculate the pulse position in the fiber and correlate what it sees in backscattered light with an actual location in the fiber. Thus it can create a display of the amount of backscattered light at any point in the fiber.
- Since the pulse is attenuated in the fiber as it passes along the fiber and suffers loss in connectors and splices, the amount of power in the test pulse decreases as it passes along the fiber in the cable

plant under test. Thus the portion of the light being backscattered will be reduced accordingly, producing a picture of the actual loss occurring in the fiber. Some calculations are necessary to convert this information into a display, since the process occurs twice, once going out from the OTDR and once on the return path from the scattering at the test pulse.

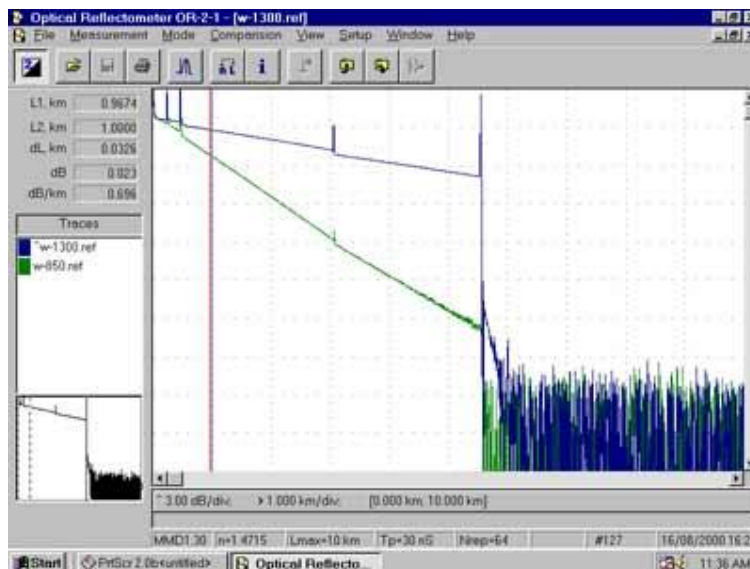

- There is a lot of information in an OTDR display. The slope of the fiber trace shows the attenuation coefficient of the fiber and is calibrated in dB/km by the OTDR. In order to measure fiber attenuation, you need a fairly long length of fiber with no distortions on either end from the OTDR resolution or overloading due to large reflections. If the fiber looks nonlinear at either end, especially near a reflective event like a connector, avoid that section when measuring loss.

- **Connectors and splices are called "events" in OTDR jargon. Both should show a loss, but connectors and mechanical splices will also show a reflective peak so you can distinguish them from fusion splices. Also, the height of that peak will indicate the amount of reflection at the event, unless it is so large that it saturates the OTDR receiver. Then peak will have a flat top and tail on the far end, indicating the receiver was overloaded. The width of the peak shows the distance resolution of the OTDR, or how close it can detect events.**

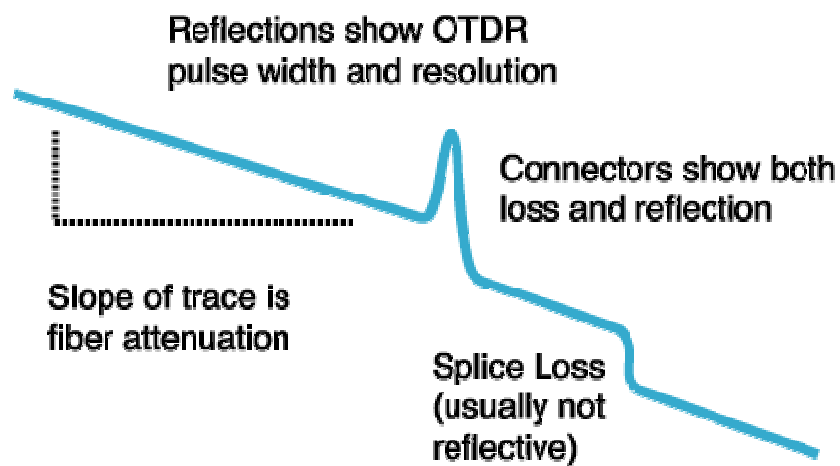

- **OTDRs can also detect problems in the cable caused during installation. If a fiber is broken, it will show up as the end of the fiber much shorter than the cable or a high loss splice at the wrong place. If excessive stress is placed on the cable due to kinking or too tight a bend radius, it will look like a splice at the wrong location.**

## **OTDR Limitations**

- **The limited distance resolution of the OTDR makes it very hard to use in a LAN or building environment where cables are usually only a few hundred meters long. The OTDR has a great deal of difficulty resolving features in the short cables of a LAN and is likely to show "ghosts" from reflections at connectors, more often than not simply confusing the user.**

## Using The OTDR

- **When using an OTDR, there are a few cautions that will make testing easier and more understandable. First always use a long launch cable, which allows the OTDR to settle down after the initial pulse and provides a reference cable for testing the first connector on the cable. Always start with the OTDR set for the shortest pulse width for best resolution and a range at least 2 times the length of the cable you are testing. Make an initial trace and see how you need to change the parameters to get better results.**



## Restoration

- **The time may come when you have to troubleshoot and fix the cable plant. If you have a critical application or lots of network cable, you should be ready to do it yourself. Smaller networks can rely on a contractor. If you plan to do it yourself, you need to have equipment ready (extra cables, mechanical splices, quick termination connectors, etc., plus test equipment.) and someone who knows how to use it.**
- **We cannot emphasize more strongly the need to have good documentation on the cable plant. If you don't know where the cables go, how long they are or what they tested for loss, you will be spinning you wheels from the get-go. And you need tools to diagnose problems and fix them, and spares including a fusion splicer or some mechanical splices and spare cables. In fact, when you install cable, save the leftovers for restoration!**
- **And the first thing you must decide is if the problem is with the cables or the equipment using it. A simple power meter can test sources for output and receivers for input and a visual tracer will check for fiber continuity. If the problem is in the cable plant, the OTDR is the next tool needed to locate the fault.**

# ***Glossary***

# Glossary Of Fiber Optic Terms

Here's an alphabetical glossary of fiber optic terms.

## **Absorption:**

**That portion of fiber optic attenuation resulting of conversion of optical power to heat.**

## **Analog:**

**Signals that are continually changing, as opposed to being digitally encoded.**

## **Attenuation Coefficient:**

**Characteristic of the attenuation of an optical fiber per unit length, in dB/km.**

## **Attenuation:**

**The reduction in optical power as it passes along a fiber, usually expressed in decibels (dB). See optical loss.**

## **Attenuator:**

**A device that reduces signal power in a fiber optic link by inducing loss.**

## **Average power:**

**The average over time of a modulated signal.**

**Back reflection, optical return loss:**

**Light reflected from the cleaved or polished end of a fiber caused by the difference of refractive indices of air and glass. Typically 4% of the incident light. Expressed in dB relative to incident power.**

**Backscattering:**

**The scattering of light in a fiber back toward the source, used to make OTDR measurements.**

**Bandwidth: The range of signal frequencies or bit rate within which a fiber optic component, link or network will operate.**

**Bending loss, microbending loss:**

**Loss in fiber caused by stress on the fiber bent around a restrictive radius.**

**Bit-error rate (BER):**

**The fraction of data bits transmitted that are received in error.**

**Bit:**

**An electrical or optical pulse that carries information.**

**Buffer:**

**A protective coating applied directly on the fiber.**

**Cable:**

**One or more fibers enclosed in protective coverings and strength members.**

**Cable Plant, Fiber Optic:**

**The combination of fiber optic cable sections, connectors and splices forming the optical path between two terminal devices.**

**CATV:**

**An abbreviation for Community Antenna Television or cable TV.**

**Chromatic dispersion:**

**The temporal spreading of a pulse in an optical waveguide caused by the wavelength dependence of the velocities of light.**

**Cladding:**

**The lower refractive index optical coating over the core of the fiber that "traps" light into the core.**

**Connector:**

**A device that provides for a demountable connection between two fibers or a fiber and an active device and provides protection for the fiber.**

**Core:**

**The center of the optical fiber through which light is transmitted.**

**Coupler:**

**An optical device that splits or combines light from more than one fiber.**

**Cutback method:**

**A technique for measuring the loss of bare fiber by measuring the optical power transmitted through a long length then cutting back to the source and measuring the initial coupled power.**

**Cutoff wavelength:**

**The wavelength beyond which singlemode fiber only supports one mode of propagation.**

**dBm:**

**Optical power referenced to 1 milliwatt.**

**Decibel (dB):**

**A unit of measurement of optical power which indicates relative power on a logarithmic scale, sometimes called dBr.  $dB = 10 \log (\text{power ratio})$**

**Detector:**

**A photodiode that converts optical signals to electrical signals.**

**Digital:**

**Signals encoded into discrete bits.**

**Dispersion:**

**The temporal spreading of a pulse in an optical waveguide. May be caused by modal or chromatic effects.**

**EDFA:**

**Erbium-doped fiber amplifier, an all optical amplifier for 1550 nm SM transmission systems.**

**Edge-emitting diode (E-LED):**

**A LED that emits from the edge of the semiconductor chip, producing higher power and narrower spectral width.**

**End finish:**

**The quality of the end surface of a fiber prepared for splicing or terminated in a connector.**

**Equilibrium modal distribution (EMD):**

**Steady state modal distribution in multimode fiber, achieved some distance from the source, where the relative power in the modes becomes stable with increasing distance.**

**ESCON:**

**IBM standard for connecting peripherals to a computer over fiber optics. Acronym for Enterprise System Connection.**

**Excess loss:**

**The amount of light lost in a coupler, beyond that inherent in the splitting to multiple output fibers.**

**Fiber Amplifier:**

**an all optical amplifier using erbium or other doped fibers and pump lasers to increase signal output power without electronic conversion.**

**Fiber Distributed Data Interface, FDDI:**

**100 Mb/s ring architecture data network.**

**Ferrule:**

**A precision tube which holds a fiber for alignment for interconnection or termination. A ferrule may be part of a connector or mechanical splice.**

**Fiber tracer:**

**An instrument that couples visible light into the fiber to allow visual checking of continuity and tracing for correct connections.**

**Fiber identifier:**



**A device that clamps onto a fiber and couples light from the fiber by bending, to identify the fiber and detect high speed traffic of an operating link or a 2 kHz tone injected by a test source.**

**Fiber optics:**

**Light transmission through flexible transmissive fibers for communications or lighting.**

**FO:**

**Common abbreviation for "fiber optic."**

**Fresnel reflection, back reflection, optical return loss:**

**Light reflected from the cleaved or polished end of a fiber caused by the difference of refractive indices of air and glass. Typically 4% of the incident light.**

**Fusion splicer:**

**An instrument that splices fibers by fusing or welding them, typically by electrical arc.**

**Graded index (GI):**

**A type of multimode fiber which used a graded profile of refractive index in the core material to correct for dispersion.**

**Index of refraction:**

**A measure of the speed of light in a material.**

**Index matching fluid:**

**A liquid used of refractive index similar to glass used to match the materials at the ends of two fibers to reduce loss and back reflection.**

**Index profile:**

**The refractive index of a fiber as a function of cross section.**

**Insertion loss:**

**The loss caused by the insertion of a component such as a splice or connector in an optical fiber.**

**Jacket:**

**The protective outer coating of the cable.**

**Jumper cable:**

**A short single fiber cable with connectors on both ends used for interconnecting other cables or testing.**

**Laser diode, ILD:**

**A semiconductor device that emits high powered, coherent light when stimulated by an electrical current. Used in transmitters for singlemode fiber links.**

**Launch cable:**

**A known good fiber optic jumper cable attached to a source and calibrated for output power used as a reference cable for loss testing. This cable must be made of fiber and connectors of a matching type to the cables to be tested.**

**Light-emitting diode, LED:**

**A semiconductor device that emits light when stimulated by an electrical current. Used in transmitters for multimode fiber links.**

**Link, fiber optic:**

**A combination of transmitter, receiver and fiber optic cable connecting them capable of transmitting data. May be analog or digital.**

**Long wavelength:**

**A commonly used term for light in the 1300 and 1550 nm ranges.**

**Loss, optical:**

**The amount of optical power lost as light is transmitted through fiber, splices, couplers, etc.**

**Loss budget:**

**The amount of power lost in the link. Often used in terms of the maximum amount of loss that can be tolerated by a given link.**

**Margin:**

**The additional amount of loss that can be tolerated in a link.**

**Mechanical splice:**

**A semi-permanent connection between two fibers made with an alignment device and index matching fluid or adhesive.**

**Micron (\*m):**

**A unit of measure,  $10^{-6}$  m, used to measure wavelength of light.**

**Microscope, fiber optic inspection:**

**A microscope used to inspect the end surface of a connector for flaws or contamination or a fiber for cleave quality.**

**Modal dispersion:**

**The temporal spreading of a pulse in an optical waveguide caused by modal effects.**

**Mode field diameter:**

**A measure of the core size in singlemode fiber.**

**Mode filter:**

**A device that removes optical power in higher order modes in fiber.**

**Mode scrambler:**

**A device that mixes optical power in fiber to achieve equal power distribution in all modes.**

**Mode stripper:**

**A device that removes light in the cladding of an optical fiber.**

**Mode:**

**A single electromagnetic field pattern that travels in fiber.**

**Multimode fiber:**

**A fiber with core diameter much larger than the wavelength of light transmitted that allows many modes of light to propagate. Commonly used with LED sources for lower speed, short distance links.**

**Nanometer (nm):**

**A unit of measure ,  $10^{-9}$  m, used to measure the wavelength of light.**

**Network:**

**A system of cables, hardware and equipment used for communications.**

**Numerical aperture (NA):**

**A measure of the light acceptance angle of the fiber.**

**Optical amplifier:**

**A device that amplifies light without converting it to an electrical signal.**

**Optical fiber:**

**An optical waveguide, comprised of a light carrying core and cladding which traps light in the core.**

**Optical loss test set (OLTS):**

**An measurement instrument for optical loss that includes both a meter and source.**

**Optical power:**

**The amount of radiant energy per unit time, expressed in linear units of Watts or on a logarithmic scale, in dBm (where 0 dB = 1 mW) or dB\* (where 0 dB\* = 1 microWatt).**

**Optical return loss, back reflection:**

**Light reflected from the cleaved or polished end of a fiber caused by the difference of refractive indices of air and glass. Typically 4% of the incident light. Expressed in dB relative to incident power.**

**Optical switch:**

**A device that routes an optical signal from one or more input ports to one or more output ports.**

**Optical time domain reflectometer (OTDR):**

**An instruments that used backscattered light to find faults in optical fiber and infer loss.**

**Overfilled launch:**

**A condition for launching light into the fiber where the incoming light has a spot size and NA larger than accepted by the fiber, filling all modes in the fiber.**

**Photodiode:**

**A semiconductor that converts light to an electrical signal, used in fiber optic receivers.**

**Pigtail:**

**A short length of fiber attached to a fiber optic component such as a laser or coupler.**

**Plastic optical fiber (POF):**

**An optical fiber made of plastic.**

**Plastic-clad silica (PCS) fiber:**

**A fiber made with a glass core and plastic cladding.**

**Power budget:**

**The difference (in dB) between the transmitted optical power (in dBm) and the receiver sensitivity (in dBm).**

**Power meter, fiber optic:**

**An instrument that measures optical power emanating from the end of a fiber.**

**Preform:**

**The large diameter glass rod from which fiber is drawn.**

**Receive cable:**

**A known good fiber optic jumper cable attached to a power meter used as a reference cable for loss testing. This cable must be made of fiber and connectors of a matching type to the cables to be tested.**

**Receiver:**

**A device containing a photodiode and signal conditioning circuitry that converts light to an electrical signal in fiber optic links.**

**Refractive index:**

**A property of optical materials that relates to the velocity of light in the material.**

**Repeater, regenerator:**



**A device that receives a fiber optic signal and regenerates it for retransmission, used in very long fiber optic links.**

**Scattering:**

**The change of direction of light after striking small particles that causes loss in optical fibers.**

**Short wavelength:**

**A commonly used term for light in the 665, 790, and 850 nm ranges.**

**Singlemode fiber:**

**A fiber with a small core, only a few times the wavelength of light transmitted, that only allows one mode of light to propagate. Commonly used with laser sources for high speed, long distance links.**

**Source:**

**A laser diode or LED used to inject an optical signal into fiber.**

**Splice (fusion or mechanical):**

**A device that provides for a connection between two fibers, typically intended to be permanent.**

**Splitting ratio:**

**The distribution of power among the output fibers of a coupler.**

**Steady state modal distribution:**

**Equilibrium modal distribution (EMD) in multimode fiber, achieved some distance from the source, where the relative power in the modes becomes stable with increasing distance.**

**Step index fiber:**

**A multimode fiber where the core is all the same index of refraction.**

**Surface emitter LED:**

**A LED that emits light perpendicular to the semiconductor chip. Most LEDs used in datacommunications are surface emitters.**

**Talkset, fiber optic:**

**A communication device that allows conversation over unused fibers.**

**Termination:**

**Preparation of the end of a fiber to allow connection to another fiber or an active device, sometimes also called "connectorization".**

**Test cable:**

**A short single fiber jumper cable with connectors on both ends used for testing. This cable must be made of fiber and connectors of a matching type to the cables to be tested.**

**Test kit:**

**A kit of fiber optic instruments, typically including a power meter, source and test accessories used for measuring loss and power.**

**Test source:**

**A laser diode or LED used to inject an optical signal into fiber for testing loss of the fiber or other components.**

**Total internal reflection:**

**Confinement of light into the core of a fiber by the reflection off the core-cladding boundary.**

**Transmitter:**

**A device which includes a LED or laser source and signal conditioning electronics that is used to inject a signal into fiber.**

**VCSEL:**

**vertical cavity surface emitting laser, a type of laser that emits light vertically out of the chip, not out the edge.**

**Visual fault locator:**

**A device that couples visible light into the fiber to allow visual tracing and testing of continuity. Some are bright enough to allow finding breaks in fiber through the cable jacket.**

**Watts:**

**A linear measure of optical power, usually expressed in milliwatts (mW), microwatts ( $\mu$ W) or nanowatts (nW).**

**Wavelength:**

**A measure of the color of light, usually expressed in nanometers (nm) or microns ( $\mu$ m).**

**Wavelength division multiplexing (WDM):**

**A technique of sending signals of several different wavelengths of light into the fiber simultaneously.**

**Working margin:**

**The difference (in dB) between the power budget and the loss budget (i.e. the excess power margin).**

# ***Additional information***

## Understanding OTDRs

- **Using test instrumentation to test your fiber optic cable plant without understanding how they work can be disastrous. While today's instruments are accurate and easy to use, they all require adequate knowledge of their operation and "quirks" to get good data. As an example, we have seen several instances where users of OTDRs (optical time domain reflectometers ) accepted the automatic results of the instruments without evaluating the displays (or perhaps not knowing how to interpret the displays.) The data was highly misleading and the consequences of the bad data was very costly. The reason was simply that the OTDR was being used outside of its normal operating parameters and the interpretation of the display is critical to understanding what is happening in the cable plant.**
- **In this section, we will examine the OTDR in detail and show examples of good and bad data. Then we will try to give you guidelines on using them.**
- **If you are going to use an OTDR, try to get training from the manufacturer or at least read the manufacturer's manual thoroughly - until you understand it fully. That will help you operate the unit properly. Much of the information here is not included in the manual, which generally only tells you which button to push. This article will help you understand how the instrument works, how to interpret what it is measuring and keep you from being misled by it.**

## When Do You Use OTDRs?

- It is very important to understand when you need an OTDR and when it is not appropriate.
- If you are installing an outside plant network such as a long distance network or a long campus LAN with splices between cables, you will want an OTDR to check if the fibers and splices are good. The OTDR can see the splice after it is made and confirm it's performance. It can also find stress problems in the cables caused by improper handling during installation. If you are doing restoration after a cable cut, the OTDR will help find the location of cut and help confirm the quality of temporary and permanent splices to restore operation. On singlemode fibers where connector reflections are a concern, the OTDR will pinpoint bad connectors easily.
- OTDRs should not be used to measure cable plant loss. That is the job of the source and power meter, which duplicates the actual fiber optic link, as we described in the first part of this article and is documented by every standard ever written for cable plant loss. The loss measured will not correlate between the two methods; the OTDR cannot show the actual cable plant loss that the system will see.
- The limited distance resolution of the OTDR makes it very hard to use in a LAN or building environment, where cables are usually only a few hundred feet long. The OTDR has a great deal of

**difficulty resolving features in the short cables of a LAN and is more often than not simply confusing to the user.**

- **Since OTDRs are very expensive and have only specific uses, the decision to buy one must be made carefully. For that reason, most instrument rental companies will rent one for a few days or weeks when you need them. However, if you are not familiar with their operation or cannot understand the results of OTDR tests, it would be much better to hire a specialist to do the testing for you.**



## How Does an OTDR work?

- Unlike sources and power meters which measure the loss of the fiber optic cable plant directly, the OTDR works indirectly. The source and meter duplicate the transmitter and receiver of the fiber optic transmission link, so the measurement correlates well with actual system loss. The OTDR, however, uses a unique phenomena of fiber to imply loss.
- The biggest factor in optical fiber loss is scattering. It is like billiard balls bouncing off each other, but occurs on an atomic level between photons (particles of light) and atoms or molecules. If you have ever noticed the beam of a flashlight shining through foggy or smokey air, you have seen scattering. Scattering is very sensitive to the color of the light, so as the wavelength of the light gets longer, toward the red end of the spectrum, the scattering gets less. Very much less in fact, by a factor of the wavelength to the fourth power - that's squared-squared. Double the wavelength and you cut the scattering by sixteen times!
- You can see this wavelength sensitivity by going outside on a sunny day and looking up. The sky is blue because the sunlight filtering through the atmosphere scatters like light in a fiber. Since the blue light scatters more, the sky takes on a hazy blue cast.

## Scattering in an optical fiber

### Scattering in an optical fiber

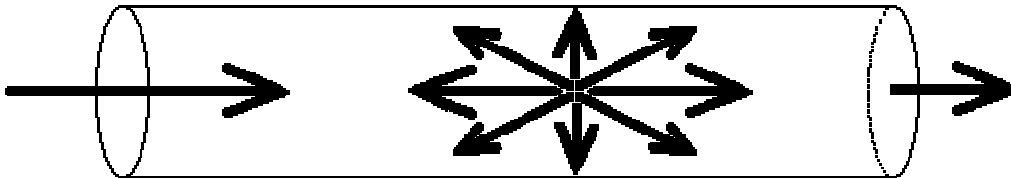

- In the fiber, light is scattered in all directions, including back toward the source as shown in the picture above. The OTDR uses this "backscattered light" to make its measurements. It sends out a very high power pulse and measures the light coming back. At any point in time, the light the OTDR sees is the light scattered from the pulse passing through a region of the fiber. Think of the OTDR pulse as being a "virtual source" that is testing all the fiber between itself and the OTDR as it moves down the fiber. Since it is possible to calibrate the speed of the pulse as it passes down the fiber, the OTDR can correlate what it sees in backscattered light with an actual location in the fiber. Thus it can create a display of the amount of

**backscattered light at any point in the fiber, see the figure below.**

## **OTDR Display**

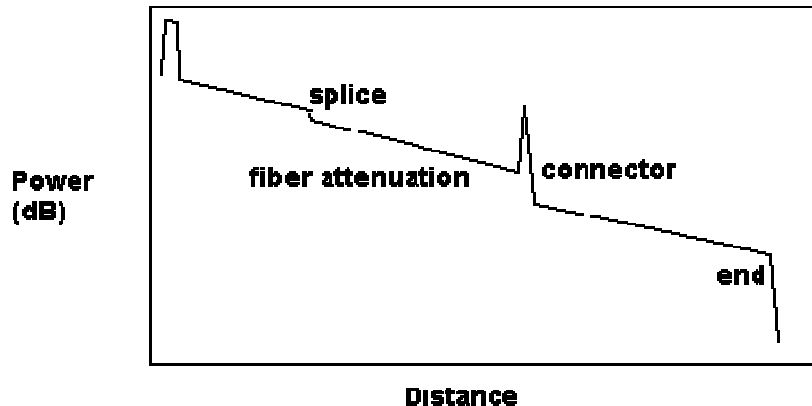

- **There are some calculations involved. Remember the light has to go out and come back, so you have to factor that into the time calculations, cutting the time in half and the loss calculations, since the light sees loss both ways. The power loss is a logarithmic function, so the power is measured in dB.**
- **The amount of light scattered back to the OTDR is proportional to the backscatter of the fiber, peak power of the OTDR test pulse and the length of the pulse sent out. If you need more backscattered light to get good measurements, you can increase the pulse peak power or pulse width as shown in the following figure.**

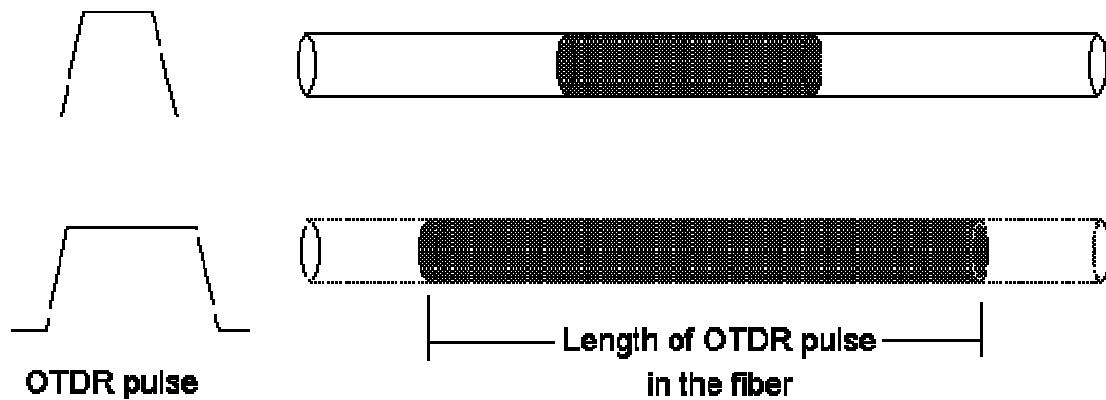

- **Note on the display shown in Figure 2, some events like connectors show a big pulse above the backscatter trace. That is a reflection from a connector, splice or the end of the fiber. They can be used to mark distances or even calculate the "back reflection" of connectors or splices, another parameter we want to test in singlemode systems.**

## Information in the OTDR Trace

- They say a picture is worth a thousand words, and the OTDR picture (or "trace" as they are called) takes a lot of words to describe all the information in it! Consider the trace in the following figure.

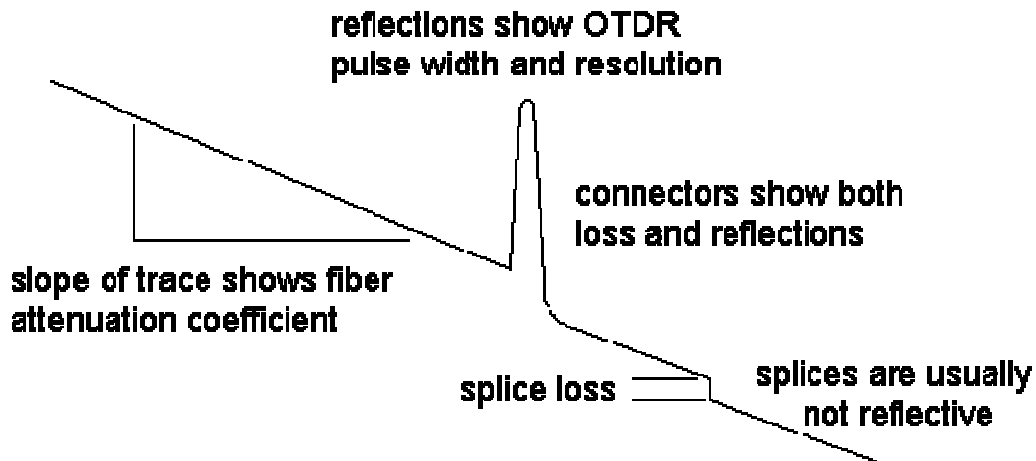

- The slope of the fiber trace shows the attenuation coefficient of the fiber and is calibrated in dB/km by the OTDR. In order to measure fiber attenuation, you need a fairly long length of fiber with no distortions on either end from the OTDR resolution or overloading due to large reflections. If the fiber looks nonlinear at either end, especially near a reflective event like a connector, avoid that section when measuring loss.
- Connectors and splices are called "events" in OTDR jargon. Both should show a loss, but connectors and mechanical splices will also show a reflective peak. The height of that peak will indicate the amount of reflection at the event, unless it is so large that it saturates the OTDR

- receiver. Then peak will have a flat top and tail on the far end, indicating the receiver was overloaded.
- Sometimes, the loss of a good fusion splice will be too small to be seen by the OTDR. That's good for the system but can be confusing to the operator. It is very important to know the lengths of all fibers in the network, so you know where to look for events and won't get confused when unusual events show up (like ghosts, we'll describe below.)
  - Reflective pulses can show you the resolution of the OTDR. You cannot see two events closer than is allowed by the pulse width. Generally longer pulse widths are used to be able to see farther along the cable plant and narrower pulses are used when high resolution is needed, although it limits the distance the OTDR can see.

## **Understanding the Physics (and Errors) of the Measurement**

- **Don't let the title put you off, it's pretty basic. The amount of light scattered back to the OTDR for measurement is quite small, about one-millionth of what is in the test pulse, and it is not necessarily constant. This affects the operation and accuracy of OTDR measurements.**

## Overload Recovery

- Since so little of the light comes back to the OTDR for analysis, the OTDR receiver circuit must be very sensitive. That means that big reflections, which may be one percent of the outgoing signal, will saturate the receiver, or overload it. Once saturated, the receiver requires some time to recover, and until it does, the trace is unreliable for measurement as shown in the following figure.

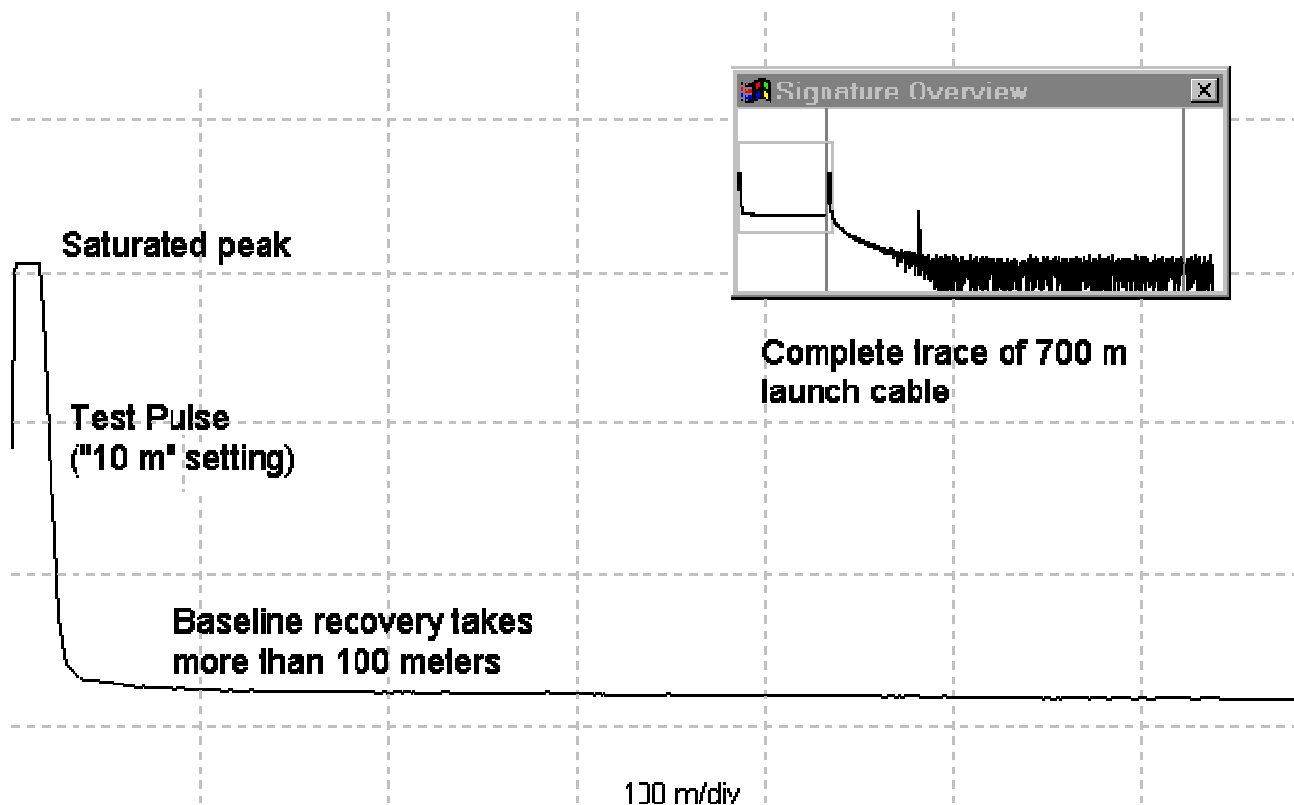

- The most common place you see this as a problem is caused by the connector on the OTDR itself. The reflection causes an overload which can take the equivalent of 50 meters to one kilometer (170 to 3000 feet) to recover fully, depending on the OTDR design, wavelength and magnitude of the



reflection. It is usually called the "Dead Zone". For this reason, most OTDR manuals suggest using a "pulse suppresser" cable, which doesn't suppress pulses, but simply gives the OTDR time to recuperate before you start looking at the fiber in the cable plant you want to test. They should be called "launch" cables.

- Do not ever use an OTDR without this launch cable! You always want to see the beginning of the cable plant and you cannot do it without a launch cable. It allows the OTDR to settle down properly and gives you a chance to see the condition of the initial connector on the cable plant. It should be long, at least 500 to 1000 meters (1640 to 3280 feet) to be safe, and the connectors on it should be the best possible to reduce reflections. They must also match the connectors being tested, if they use any special polish techniques.

## Ghosts

- **If you are testing short cables with highly reflective connectors, you will likely encounter "ghosts" like in the following figure. These are caused by the reflected light from the far end connector reflecting back and forth in the fiber until it is attenuated to the noise level. Ghosts are very confusing, as they seem to be real reflective events like connectors, but will not show any loss. If you find a reflective event in the trace at a point where there is not supposed to be any connection, but the connection from the launch cable to the cable under test is highly reflective, look for ghosts at multiples of the length of the launch cable or the first cable you test. You can eliminate ghosts by reducing the reflections, using a trick we will share later.**

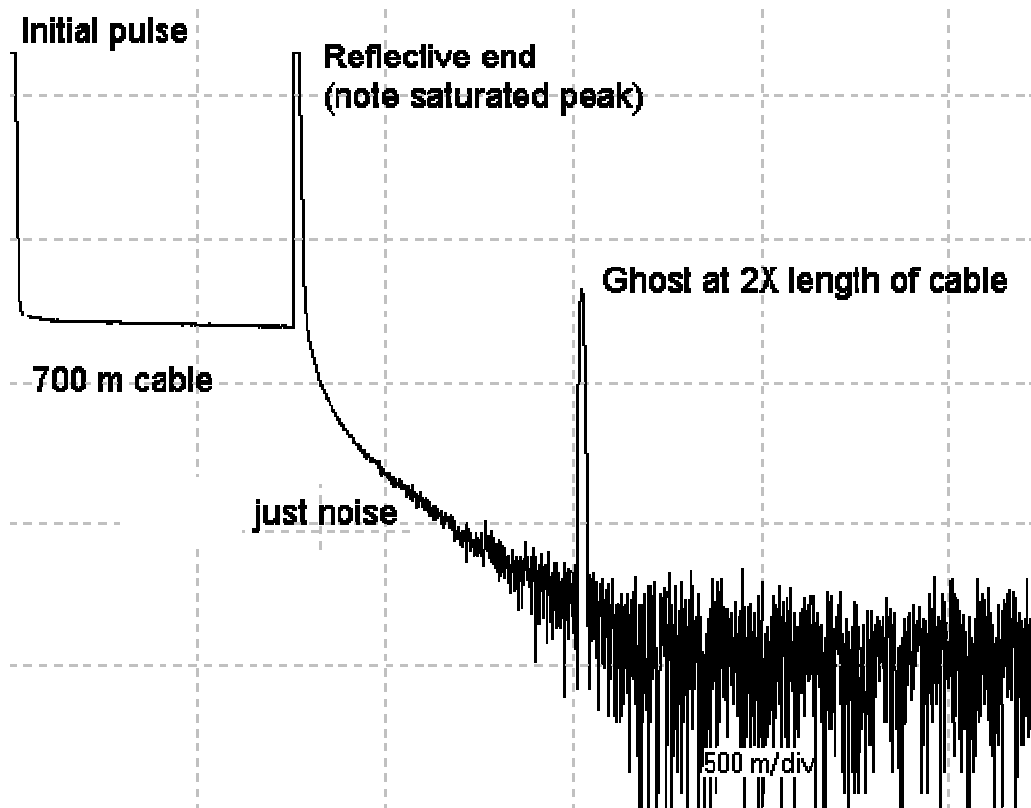

- **On very short cables, multiple reflections can really confuse you! We once saw a cable that was tested with an OTDR and deemed bad because it was broken in the middle. In fact it was very short and the ghosted image made it look like a cable with a break in the middle. The tester had not looked at the distance scale or he would have noted the "break" was at 40 meters (131 feet) and the cable was only 40 meters long. The ghost at 80 meters (262 feet) looked like the end of the cable to him!**

## **Backscatter Variability Errors**

- **Another problem that occurs is a function of the backscatter coefficient, a big term which simply means the amount of light from the outgoing test pulse that is scattered back toward the OTDR. The OTDR looks at the returning signal and calculates loss based on the declining amount of light it sees coming back.**
- **Only about one-millionth of the light is scattered back for measurement, and that amount is not a constant. The backscattered light is a function of the attenuation of the fiber and the diameter of the core of the fiber. Higher attenuation fiber has more attenuation because the glass in it scatters more light. If you look at two different fibers connected together in an OTDR and try to measure splice or connector loss, you have a major source of error, the difference in backscattering from each fiber.**
- **To more easily understand this problem, consider the figure below showing two fibers connected. If both fibers are identical, such as splicing a broken fiber back together, the backscattering will be the same on both sides of the joint, so the OTDR will measure the actual splice loss.**

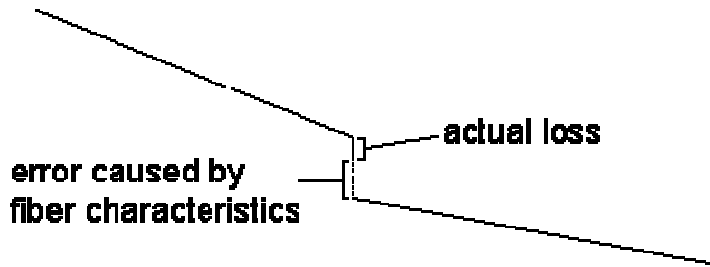
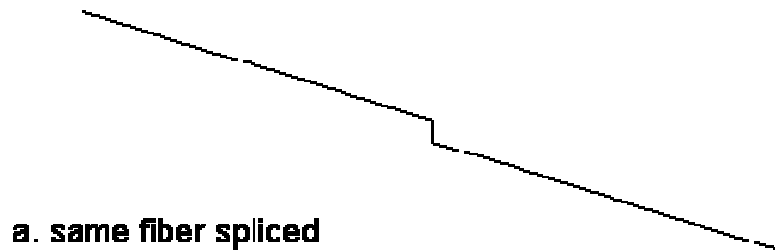

**b. high loss fiber spliced to low loss fiber**

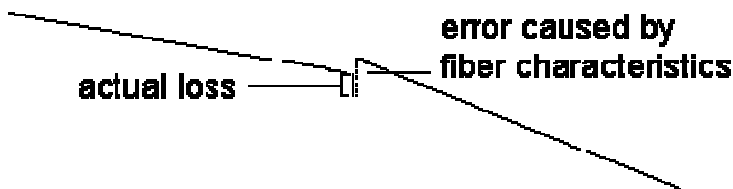

**c. low loss fiber spliced to high loss fiber  
can cause an apparent gain at a splice**

- **However, if the fibers are different, the backscatter coefficients will cause a different percentage of light to be sent back to the OTDR. If the first fiber has more loss than the one after the connection, the percentage of light from the OTDR test pulse will go down, so the measured loss on the OTDR will**

**include the actual loss plus a loss error caused by the lower backscatter level, making the displayed loss greater than it actually is.**

- **Looking the opposite way, from a low loss fiber to a high loss fiber, we find the backscatter goes up, making the measured loss less than it actually is. In fact, this often shows a "gainer", a major confusion to new OTDR users.**
- **The difference in backscatter can be a major source of error. A difference in attenuation of 0.1 dB per km in the two fibers can lead to a splice loss error of 0.25 dB! While this error source is always present, it can be practically eliminated by taking readings both ways and averaging the measurements, and many OTDRs have this programmed in their measurement routines. This is the only way to test inline splices for loss and get accurate results.**
- **Another common error can come from backscatter changes caused by variations in fiber diameter. A variation in diameter of 1% can cause a 0.1 dB variation in backscatter. This can cause tapered fibers to show higher attenuation in one direction, or we have in the past seen fiber with "waves" in the OTDR trace caused by manufacturing variations in the fiber diameter.**

## **Overcoming Backscatter Errors**

- **One can overcome these variations in backscatter by measuring with the OTDR in both directions and averaging the losses. The errors in each direction cancel out, and the average value is close to the true value of the splice or connector loss. Although this invalidates the main selling point of the OTDR, that it can measure fiber from only one end, you can't change the laws of physics.**

## Resolution Limitations

- The next thing you must understand is OTDR resolution. The OTDR test pulse, see the following figure, has a long length in the fiber, typically 5 to 500 meters long (17 to 1700 feet). It cannot see features in the cable plant closer together than that, since the pulse will be going through both simultaneously. This has always been a problem with LANs or any cable plant with patchcords, as they disappear into the OTDR resolution. Thus two events close together can be measured as a single event, for example a connector that has a high loss stress bend near it will show up on the OTDR as one event with a total loss of both events. While it may lead you to think the connector is bad and try to replace it, the actual problem will remain.
- Another place this problem shows up is in splice closures. An OTDR may show a bad splice, but it can actually be a crack or stress point somewhere else in the splice closure.

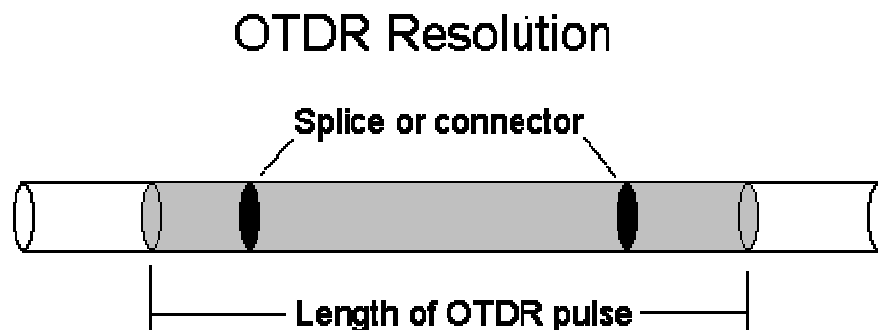

- There is a tool that will help here. It is called a "visual fault locator". It injects a bright red laser



**light into the fiber to find faults. If there is a high loss, such as a bad splice, connector or tight bend stressing the fiber, the light lost may be visible to the naked eye. This will find events close to the OTDR or close to another event that are not resolvable to the OTDR. It's limitation is distance too, it only works over a range of about 2.5 miles or 4 km.**

- **The visual fault locator is so valuable a tool that many OTDRs now have one built into them. If you are using an OTDR, you must have one to use it effectively.**

## Special Consideration for Multimode Fiber

- **Most OTDR measurements are made with singlemode fiber, since most outside plant cable is singlemode. But building and campus cabling are usually multimode fiber using light emitting diode sources for low and medium speed networks. The OTDR has problems with multimode fiber, since it uses a laser source to get the high power necessary to cause high enough backscatter levels to measure.**
- **The laser light is transmitted by multimode fiber only in the center of the core (figure below) because its emission angle is so low. LEDs, however, are transmitted throughout the core of the multimode fiber, due to their wider radiation pattern. As a result of the OTDR light being concentrated in the center of the fiber, the loss of connectors is lower because the typical connector offset errors are not an effect. And even the fiber has lower loss, because the light in the center of the core travels a shorter path than the light at the outer edges of the core.**

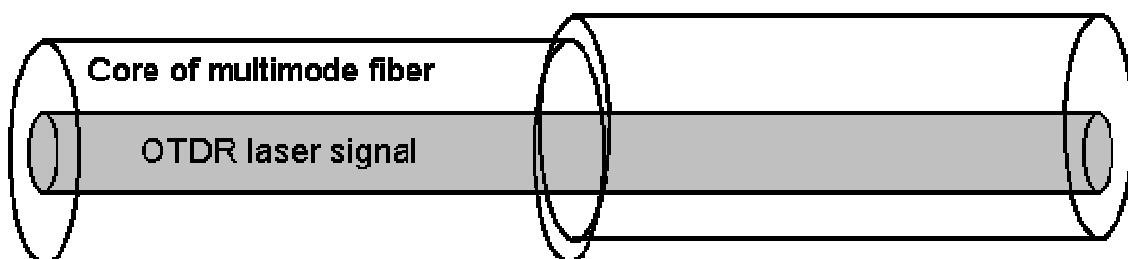

- **Several projects have tried to determine how to correlate OTDR measurements to source and power meter measurements, without success. Our experience is an OTDR will measure 6-7 dB of loss for a multimode cable plant that tests at 10 dB with a source and power meter.**

## Measuring Fiber, not Cable Distance

- **And finally, OTDRs measure fiber not cable length. While this may sound obvious, it causes a lot of problems in buried cable. You see, to prevent stress on the fiber, cable manufacturers put about 1% more fiber in the cable than the length of the cable itself, to allow for some "stretch." If you measure with the OTDR at 1000 meters(3300 feet), the actual cable length is about 990 meters (3270 feet). If you are looking for a spot where the rats chewed through your cable, you could be digging 10 meters (33 feet) from the actual location!**

## **Examples of How to Use the OTDR and Avoid Errors**

- **Here are some actual examples of how to use an OTDR properly (and improperly) and some tricks to overcome some of the problems you encounter. The most adamant advice we will give is this: Do not blindly accept the data without interpretation. Most of today's OTDRs have "automatic modes" where they will find splices and connectors and calculate all the losses, if the data follows preprogrammed guidelines. In our experience, these numbers are not to be used without human interpretation of the results, as the OTDR is basically a PC, isn't too smart, and the software has limitations if the cable plant has high reflections or short cable runs.**

## What Does a Good OTDR Trace Look Like?

- Take a look at the figure below. You can see the end of the "pulse suppressor" cable, the first fiber out from the OTDR, allows time for the OTDR to recover from the initial pulse. Note the fibers are all straight lines between "events, as splices and connectors are called in OTDR jargon. Markers for loss measurements should always be set far enough on either side of an event to be on the straight part of the fiber trace. If there is any curve, it is likely caused by the resolution of the OTDR or recovery from an overload.

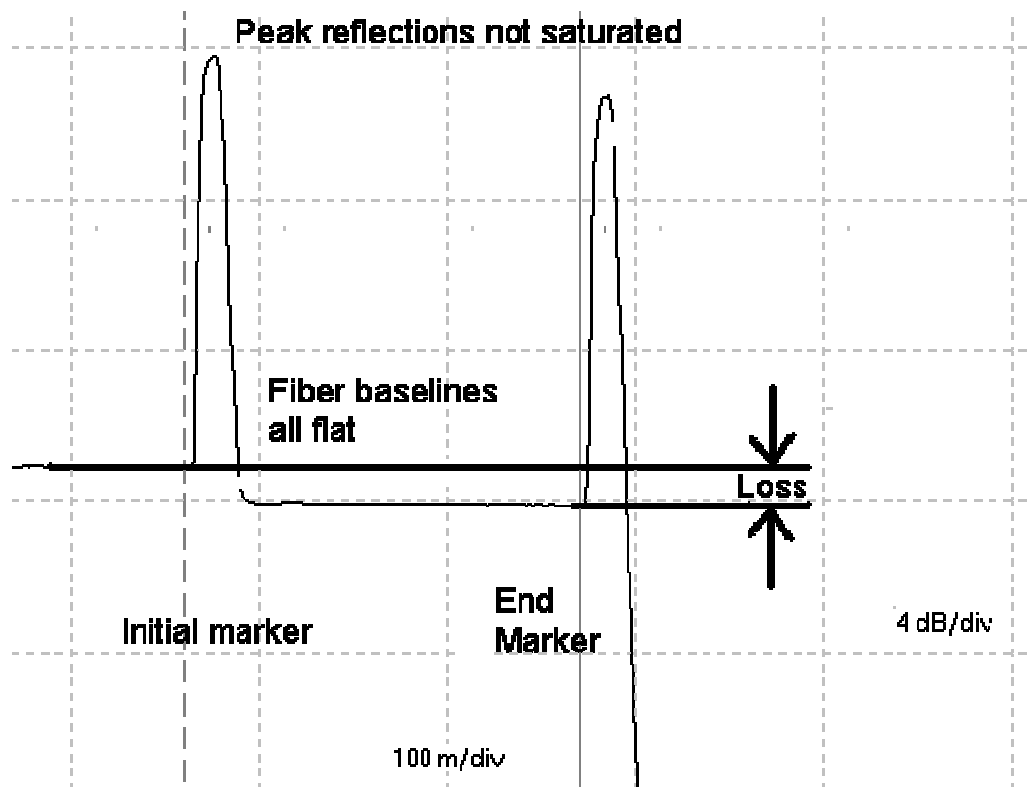

- Setting the markers slightly away from the event won't affect the loss measurement by adding

**significant fiber loss. Remember fiber loss is only 0.01 dB per 10 meters (33 feet) at 1300 nm! By going further from the event, you reduce the possibility that the measurement is in error because of instrument limitations.**

- **If the trace never shows a straight line between events, it means either the distance between events is too short for the OTDR resolution or reflections are too high for the recovery time needed before the next event. In this case, you cannot get good data on either fiber loss or event loss.**

## **This "Trick" Can Help**

- **There is a trick you can try if you are desperate. The reflection at an event that causes overloading the OTDR receiver can be tamed by using "index matching fluid" to reduce the effect that causes the reflection. The reflection is caused by an air gap between the ends of the fibers. Connectors are particularly bad at having this air gap and resulting high reflections. An index matching fluid replaces the air with a fluid or gel that closely matches the optical characteristics of the glass, causing the reflections to be greatly diminished.**
- **The following figure shows two traces of the same fiber. It is only 700 feet or 200 meters long, which is normally considered quite short for OTDR analysis. The initial trace shows the connector on the OTDR end has high reflections, saturating the OTDR and causing the baseline of the trace to decay slowly. Even the second pulse, from the connector at the far end of the cable has very high reflections. Both reflections caused ghosts also.**
- **Since the baseline between the two ends never becomes flat or straight, there is no reliable reference point for making a loss measurement.**
- **But we can reduce the reflections by adding index matching fluid. We just add a drop of gel or fluid between the two connectors that matches the index of reflection of the glass in the fiber, reducing the reflections. Once we reduce the reflections, causing the receiver overload to go away, the OTDR will**



**give us a good fiber trace just beyond the connector and a flat fiber trace which we can use for measuring the actual loss! We even got rid of the confusing ghosts!**

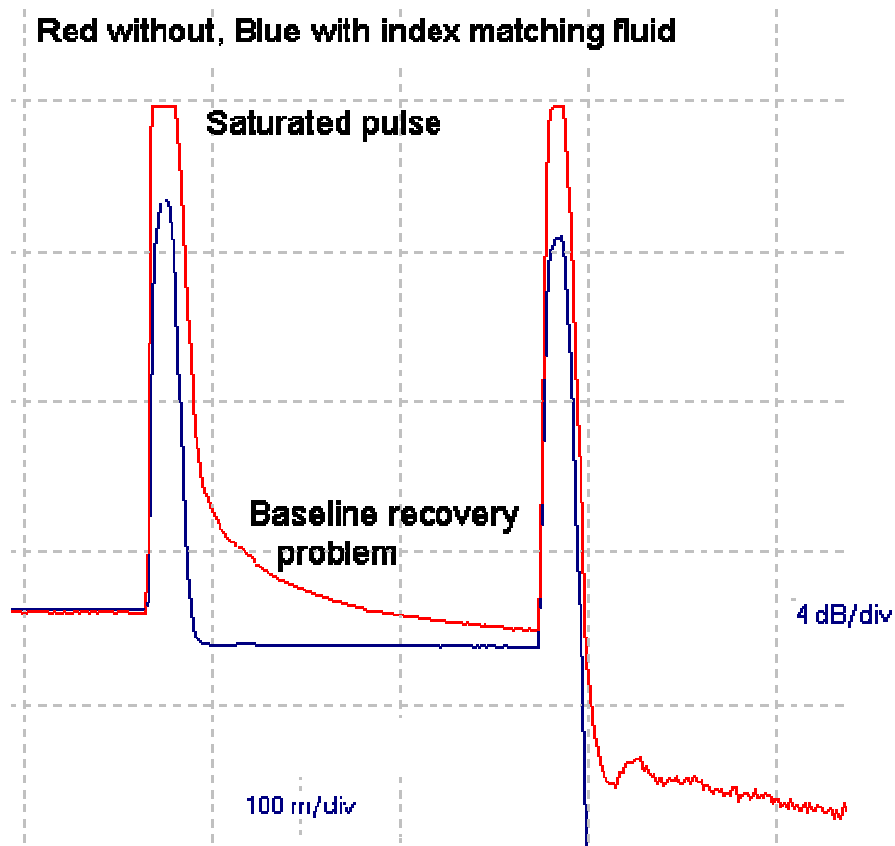

- **Index matching fluid can be purchased from a specialty fiber optic distributor or from your local supermarket or druggist. The special fluids work very well but are expensive. Mineral oil or plain petroleum jelly work almost as well! If you can get silicone "high vacuum grease", it works very well too.**
- **Using this technique gives us visibility we would never have otherwise, but the technique requires care. The index matching fluid or gel must be thoroughly cleaned from the connectors after use**

**with the OTDR. The splice bushing used must not be one in the network hardware, but a separate item that can be used and discarded or thoroughly cleaned in solvent afterwards. Index matching fluid or gel will act like a magnet for dirt if it gets on any hardware or stays on the connectors, as its sticky texture will grab and hold lots of airborne dirt to attenuate the signal in the fiber link.**

## Summary

- **Testing fiber optic cable plants are easy if you have the right instruments and follow industry testing standards. When diagnosing problems, you must be creative to develop techniques that help reveal problems that show up on standard tests. It is most important to know your tools operation and limitations, and how to work around them. Get to know the applications support staff at your instrument vendor so you can call with questions. Finally, it is most helpful to have good cable plant documentation, since knowing what you are looking at will make it much easier to find problems.**

# Notes

.....

.....

.....

.....

.....

.....

.....

.....

.....

.....

.....

.....

.....

.....

.....

.....

.....

.....

.....

.....









**AFS Europe**  
**Postbus 111**  
**3780 BC Voorthuizen**

**Tel:** 00-31-342-470734

**Fax:** 00-31-342-422616

**Internet:** <http://www.afs-europe.com>

**Email:** [sales@afs-europe.com](mailto:sales@afs-europe.com)

[support@afs-europe.com](mailto:support@afs-europe.com)

**BTW code:** NL121102609B01

**Terms of payment and delivery published at Chamber of  
Commerce Harderwijk**

**K.v.K. nr.:** 08077470

**Rabobank:** 36.63.12.553