

AFS-EUROPE

www.afs-europe.com

OLK51-POF MANUAL

AFS-Europe

Hunnenweg 7
3781 NM Voorthuizen
The Netherlands
Tel: 00-31-342-477882
Fax: 00-31-342-422616
Web: <http://www.afs-europe.com>

P.O. Box 111
3780 BC Voorthuizen
The Netherlands

OLK51-POF Manual

Contents	Page
General Description	2
Cleaning Procedures	3
Warnings	3
OM110	4
OM110 Operation Instructions	5
Units Power Source	6
OS400 Series	7
OS417 Specifications and Operation Instructions	7
Application and Testing Guide	8/11
Watts to dB Conversion Chart	12
Calibration	12
Warranty	13

General Description:

AFS-Europe offers the complete solutions necessary for the installer to test, terminate and troubleshoot fiber optic systems. The OLK51 series is designed to allow testing of all operating parameters of fiber optic networks, including output power levels from the fiber, coupled source power and attenuation loss in a cable.

AFS-Europe offers complete test kits for both Multimode and Singlemode applications. The OLK51-POF test kit is designed for short wavelength Multimode applications from small to large core fibers.

Kit Content:

The **OLK51-POF** test kit includes the following items:

Fiber Optic Power Meter (OM110) calibrated at 665nm, 790nm and 850nm

Fiber Optic Source (OS417-MD) with a 665nm LED and a 850nm LED

Two connector adaptors

Carrying case

Instruction manual for testing fiber optic systems

*Other kit combinations exist, please visit www.afs-europe.com for more details

Add on options: The customer may also order **cable test kits** that are not in the standard kits. Reference and receive cables shall be ordered separately. The customer may also order **adaptor kits** for their specific applications.

Ask AFS-Europe sales representatives for more details.

Cleaning Procedures For Fiber Optic Cables:

Fiber optic connectors are sensitive to all types of dirt and skin oil. Because the fiber size is so small, the slightest spec of dirt can cause signal blockage and attenuation to a connector end. Always avoid touching the end of the ferrule. Always keep unconnected connectors covered with dust caps. This will ensure that the fiber does not become scratched or dirt does not settle on the end of the ferrule.

When cleaning the connector use only lint free pads or isopropyl alcohol wipes. Some solvents may attack epoxy or leave residue. All AFS-Europe test kit come provided with Texwipes Alco Pads. If a connector surface can not be cleaned with a Alco Pad because it is in a bulkhead or an active device mount use canned air. Canned air sometimes leave residue if not used with caution. Spray for 3/5 seconds to ensure that propellant is removed from the nozzle.

Other optical surfaces, like the meter detector should also be cleaned with a Texwipe when necessary. After a quick rub with the Texwipe let the surface air dry before replacing the adaptor back on the detector housing.

Warning: Never look or stare directly into a fiber optic cable.

Optical radiation that is harmful to the eye may be present. This may result in permanent eye damage. While the chances of such an occurrence taking place is very unlikely it is best advised to always use the fiber optic power meter when detecting light.

The DO's: Always use Alco Pads for cleaning fiber optic cables
 Replace dust caps on connector end when finished testing

The DONT's: Touch the end of a cable with fingers
 Leave ferrule without dust caps
 Drop the connector on its face
 Look directly into a fiber optic cable

OM110:

The OM110 meter is calibrated over three wavelengths to ± 0.2 dB of the NIST standard for each wavelength through the dynamic range of the meter. The OM110 is designed to measure loss (attenuation) and output power in both Multimode systems. The OM110 silicon detector is potted in a threaded housing for versatility. This allows the user to interchange adaptors for numerous connector styles.

Ask AFS-Europe sales representatives for more details on available adaptors.

Specifications:

Model	OM110
Calibrated Wavelength	665, 790 & 850nm
Detector	3 mm Silicon
Dynamic Range	+3dBm to -55dBm

OM110:

Accuracy à	+/- 0.2 dB Calibrated to NIST standard
Detector Housing à	Threaded for interchangeable adaptors
Display à	128x64 dot matrix display
Resolution à	0.1
Low Battery Indicator à	Yes
Auto Power Down à	Yes
Backlight à	Yes
Controls à	Five soft rubber keypads: On/Off, backlight, Range (dB&dBm), wavelength, zero ref
Serial interface à	No
Power à	2 AA's or optional AC adaptor.
Typical Life à	20 hours continuous operation (<i>typical</i>)
Case Dimensions à	4.7 x 2.7 x 1.2
Operational Temp Range à	-10Deg C to 50Deg C (45% Hum, non condensing)
Storage Temp Range à	-20Deg C to 60Deg C (45% Hum, non condensing)
Regulatory Approval à	CE

OM110 Operating instructions:

Control Key's: (All key's are rubber key pads)

1. On\Off
2. Backlight
3. Wavelength Select I (665nm, 790nm and 850nm)
4. dB\dBm
5. Zero reference (for all specified wavelengths)

Backlight Key allows the user the option to turn the display backlight on or off.

The Wavelength select key I allows the user to select between the calibrated wavelengths of the OM110. All wavelengths are calibrated to ± 0.2 dB of the NIST standard.

The dB\dBm select key allows the user to select between absolute power which is measured in dBm or relative power which is measured is dB. dBm is referenced to 1 milliwatt and both are a function of the log scale.

The Zero reference key allows the user to set the input launch power to a relative dB zero reference value for easy calculation of loss and attenuation of a fiber optic cable. For instance, if a launch cable output power value is -25.6 dBm and a test cable is inserted between the launch cable and the meter with a reading of -27.1 dBm, the user has to subtract -27.1 dBm from -25.6 dBm to get a result of -1.5 dB. As simple as this test sounds it can sometimes get confusing to the user due to the fact that they are not sure if their result should be a positive value or a negative value also miscalculation can be an issue. The zero reference function eliminates these problems. The user simply sets their reference value (which in this case is -25.6 dbm) to 0.0 dB then inserts the test cable to get a loss reading of -1.5 dB. ***EASY***

Different references can be stored for all three wavelengths. The stored reference value will be maintained until a new reference is stored.

The screen also displays the value that the user has referenced too at the bottom left corner of the screen. This reading is the dBm (absolute) value of the users dB zero reference value.

** The OM110 also offers an **auto power down** feature. This function can be enabled or disable when the unit is powered up by pressing the I key. When enabled the unit will shut down after 15 minutes of no key activity. The unit will signal the user that it is about to shut down by counting down the last minute in the right top corner of the screen.*

Power:

1. 2 AA batteries
2. *Optional AC power converter.*

The battery is in the compartment at the rear of the unit

*AC adaptors are not standard with the OLK51 test kits but may be ordered separately.
Ask AFS-Europe sales representatives for more details.*

OS400 Series:

The OS400 Series are handheld fiber optic sources. AFS-Europe offers a number of sources in this series. Please visit AFS-Europe website for more details. The OS417 source is an LED source for multimode (POF) applications. The OS417 source has two LED's. The wavelength's of the LED's are 665nm and 850nm. The 850nm LED is housed in a fixed ST adaptor (Active Device Mount) while the 665nm is housed a modulated adaptor for connector versatility.

Specifications:

Model	OS417
Wavelength	665nm, 850nm
Type	LED
Application	MM (POF)
Connector Style	Modulated & ST

OS417 Interface: Multimode Source

Control indicators and switches:

Switch à The unit has a slide switch to turn either the 850nm LED or 665nm LED on.

Indicators à 3 LEDs that indicate 850nm on, 665nm on and low battery.

Pots à The unit has adjustment pots for both the 850nm LED and the 665nm LED. Having both pots makes the unit user friendly for easy referencing of both LEDs.

OS417 Specifications:

1. Transmitters à a) 850nm Active Device Mount.
b) 665nm in modulated adaptor
2. Connector Style à Modulated & ST
3. Output Power à > -20.0 dBm (for both LED's)
4. Wavelength à 850nm and 665nm
5. Stability à +/- 0.2 dB (over a 8 hour period with 5 minute warm up)
6. Coupled Power Ratio à 850nm category 1 (Overfill) according to the TIA/EIA-526-14A Standard.
7. Batteries à 2 AA
8. Battery life à 16 Hours continuous operation (*typical*)
9. Low Battery Indicator à Yes
10. Serial Interface à No
11. Temperature à Operation -10 to +50 C (45% Hum, non condensing)
Storage -20 to +60 C (75% Hum, non condensing)
12. Regulatory Approval à CE

PRODUCT APPLICATION AND TESTING GUIDE

In the following testing guide a meter refers to an AFS-Europe OM110 and a source refers to an AFS-Europe OS417 LED source.

Setting 0 dB loss reference for testing

This is the reference power reading that is created by placing a launch cable between the meter and the source.

Test setup:

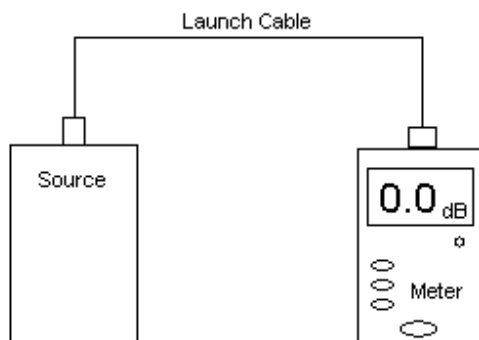

Procedure:

1. Attach launch cable to the output of the source.
2. Make sure the output power level from the source is over -30 dBm.
3. With meter in "dB" mode, hit the zero reference key. When the meter zeros out as illustrated in the above setup the launch reference power has been stored and the user is now ready to start testing cables.
4. Once the zero reference power has been set, do not remove the launch cable from the source as reattaching it may change the output power level.

Fiber Optic Cable Testing Per EIA/TIA FOTP-171

One-way loss test: Tests loss of connector mated to launch cable. To test the other connector of the test cable, reverse the cable under test.

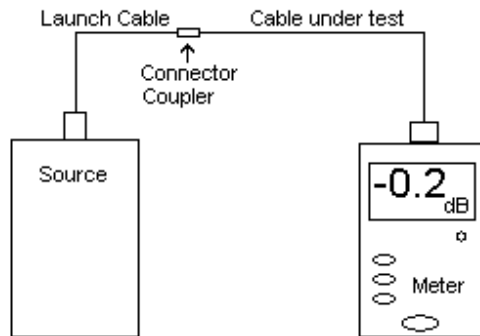

FOTP-171

Procedure:

1. Attach the test cable to the connector coupler.
2. Attach the other end of the cable to the meter and read the value.
3. The indicated value on the display will be the loss of the mated connector of the cable under test and the test cable. To test the other connector on the test cable simply reverse the cable under test and read the loss from the power meter.

Fiber Optic Cable Testing Per EIA/TIA OFSTP-14

This test allows the user to test both connectors of the cable under test at once (Dual Connector test).

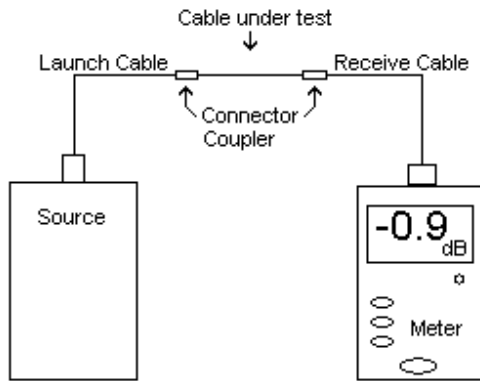

OFSTP-14

Procedure:

1. A loss reading for the receive cable should already be established by doing a single ended test on it as specified in the FOPT-171 illustration. The loss of the receive cable should be added on to the loss of the cable under test when the test is completed or zeroed out before the cable under test is placed between it and the launch cable.
2. Attach the cable under test to the launch cable.
3. Attach the other end of the cable under test to the receive cable.
4. The power indicated on the meter is the loss of the cable under test.

**When testing cables make sure that the cable under test, the receive and the launch cable have the same core and cladding size otherwise the results will not be true loss readings.*

Measuring output power of a fiber optic transmitter/system

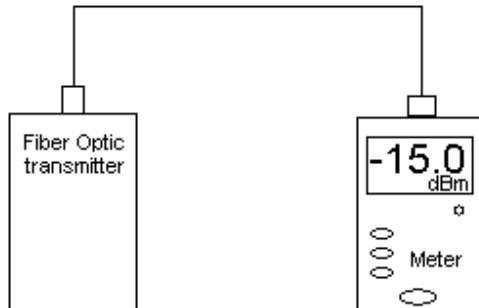

Procedure:

1. Measure output power from transmitter or at receiver by connecting to the power meter.
2. Set meter to correct wavelength.
3. Set meter to dBm for absolute power measurement.
4. Read power on meter.

Conversion Chart For dB to Watts

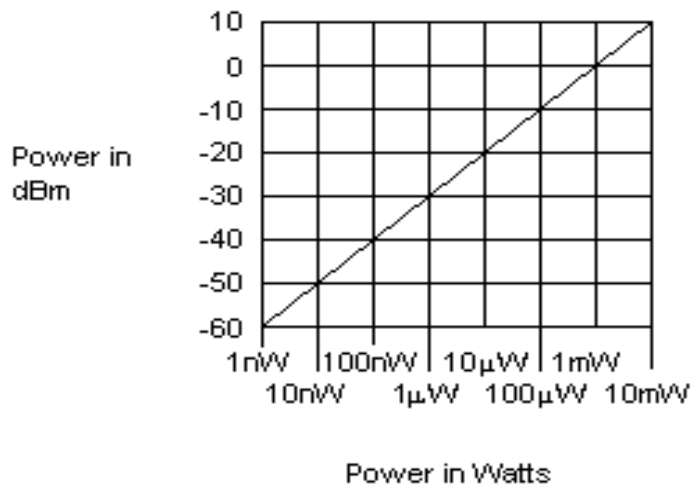

CALIBRATION:

Every AFS-Europe fiber optic power meter calibrated is NIST traceable. Calibration should be preformed yearly by returning the unit to AFS-Europe or to an AFS-Europe certified calibration house.

WARRANTY:

AFS-Europe offers a 1 year limited warranty on all units sold (unless otherwise specified). This warranty starts on the date of shipment of the product to its purchaser. AFS-Europe warrants that the product or products purchased will be free of defects in workmanship and material. AFS-Europe warrants that the product or products purchased will conform in accordance with the specifications set forth for that product or those products as published by AFS-Europe.

AFS-Europe will on written notice by the purchaser correct product/products defects by repair or replacement of that product. AFS-Europe will incur all cost to replace or repair the product/products in question if AFS-Europe deem that the product malfunction is without question due to a manufacturers defect. Correction as stated herein will absolve AFS-Europe from liability due to product defects.

AFS-Europe will not honor the warranty if the product or products in question have defects due to improper use, lack of maintenance or damage to the product or products incurred outside of the AFS-Europe facility.

AFS-Europe will in no event be liable for death, injury to persons, damage to property or equipment, loss of profits or revenues, cost of capital, claims for service interruption or cost of product replacement.

AFS-Europe liability due to product defect will never exceed the price of that product.

AFS-Europe reserves the right to make engineering improvements or changes without notice.